

Draft

DRAFT

Lecture Notes in:

FINITE ELEMENT II
Solid Mechanics

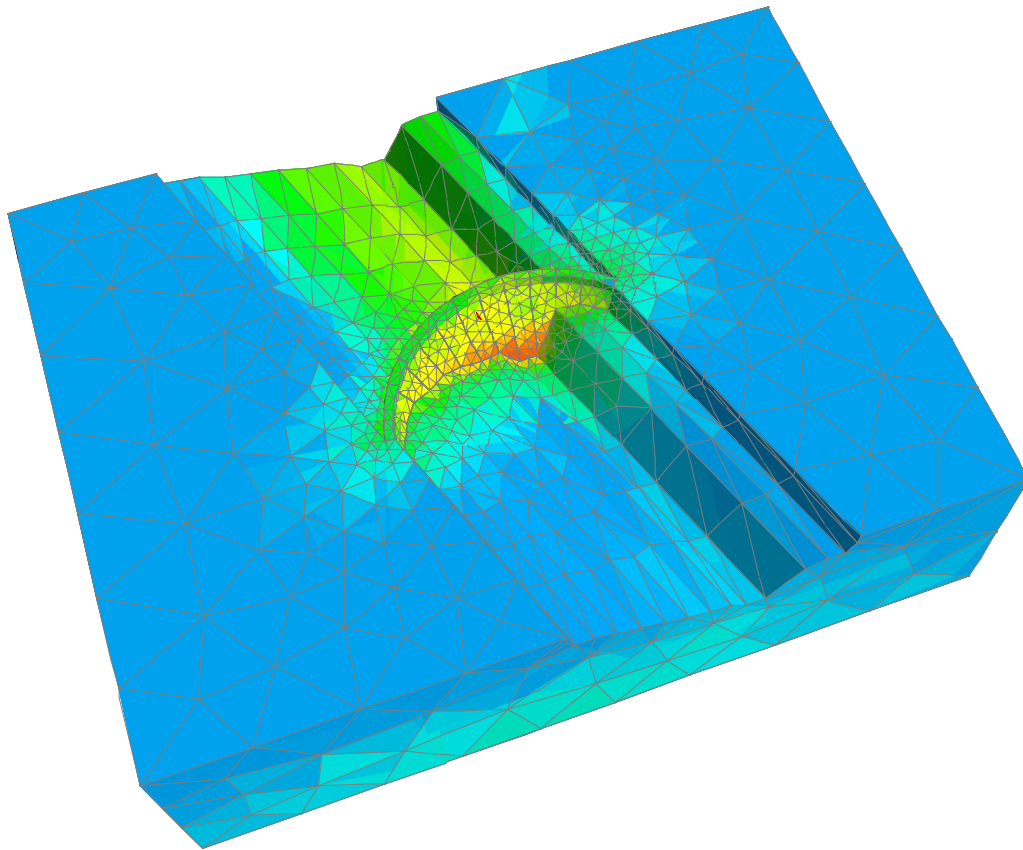

Victor E. Saouma

Dept. of Civil Environmental and Architectural Engineering

University of Colorado, Boulder, CO 80309-0428

Contents

0	PREREQUISITE	23
0.1	Variational Formulations	23
0.2	Finite Element Formulation	26
0.2.1	Strain Displacement Relations	26
0.2.1.1	Axial Members	26
0.2.1.2	Flexural Members	26
0.2.2	Virtual Displacement and Strains	26
0.2.3	Element Stiffness Matrix Formulation	27
0.2.3.1	Stress Recovery	28
0.3	Direct Stiffness Method	28
0.3.1	Global Stiffness Matrix	28
0.3.1.1	Structural Stiffness Matrix	29
0.3.1.2	Augmented Stiffness Matrix	29
0.3.2	Logistics	30
0.3.2.1	Boundary Conditions, [ID] Matrix	30
0.3.2.2	LM Vector	31
0.3.2.3	Assembly of Global Stiffness Matrix	31
E 0-1	Assembly of the Global Stiffness Matrix	32
0.3.2.4	Algorithm	33
E 0-2	Direct Stiffness Analysis of a Truss	33
E 0-3	Analysis of a Frame with MATLAB	38
E 0-4	Analysis of a simple Beam with Initial Displacements	40
1	INTRODUCTION	45
1.1	Introduction	45
1.2	Elliptic, Parabolic and Hyperbolic Equations	45
E 1-1	Seepage Problem;(Bathe 1996)	47
E 1-2	Diffusion Problem; (Bathe 1996)	48
E 1-3	Wave Equation, (Bathe 1996)	49
1.3	Solution of Discrete-System Mathematical models	51
1.3.1	Steady State Problems	51
1.3.1.1	Elastic Spring	52
1.3.1.2	Heat Transfer	53
1.3.1.3	Hydraulic Network	54
1.3.1.4	DC Network	55
1.3.2	Equivalent “Truss”/Direct Stiffness Models	55
1.3.2.1	Nonlinear Elastic Spring	58
1.3.3	Propagation Problems	58
1.3.3.1	Dynamic Elastic System	58
1.3.3.2	Transient Heat Flow	59
1.3.4	Eigenvalue Problems	60
1.3.4.1	Free Vibration	60

Draft

4	VARIATIONAL and RAYLEIGH-RITZ METHODS	97
4.1	Multifield Variational Principles	97
4.2	Total Potential Energy Principle	98
4.2.1	Static; Euler	98
4.2.2	Dynamic; Euler/Lagrange	100
E 4-1	Hamilton's Principle	101
4.3	General Hu-Washizu Variational Principle	104
4.4	Rayleigh Ritz	106
4.4.1	Examples	109
E 4-2	Uniformly Loaded Simply Supported Beam; Polynomial Approximation	109
E 4-3	Heat Conduction; (Bathe 1996)	110
5	INTERPOLATION FUNCTIONS; NATURAL COORDINATE SYSTEMS	113
5.1	Introduction	113
5.2	Cartesian Coordinate System	113
5.2.1	C^0	114
5.2.1.1	Truss element	114
5.2.1.2	Generalization	115
5.2.1.3	Constant Strain Triangle Element	115
5.2.1.4	Further Generalization: Lagrangian Interpolation Functions	117
5.2.1.5	Rectangular Bilinear Element	117
5.2.1.6	Solid Rectangular Trilinear Element	118
5.2.2	C^1	119
5.2.2.1	Flexural	119
5.2.2.2	C^1 : Hermitian Interpolation Functions	121
5.2.3	Characteristics of Shape Functions	121
5.3	Natural Coordinate System	122
5.3.1	Straight Line	122
5.3.2	Triangular Coordinates	123
5.3.3	Volume Coordinates	125
5.3.4	Interpolation Functions	126
5.4	Pascal's Triangle	127
6	FINITE ELEMENT DISCRETIZATION and REQUIREMENTS	129
6.1	Discretization	129
6.1.1	Discretization of the Variational Statement for the General TPE Variational Principle	129
6.1.2	Discretization of the Variational Statement for the HW Variational Principle	131
6.2	General Element Requirements	135
6.3	Discretization Error and Convergence Rate	136
6.4	Lower Bound Character of Minimum Potential Energy Based Solutions	137
6.5	Equilibrium and Compatibility in the Solution	137
7	STRAIGHT SIDED ELEMENTS; 1st GENERATION	139
7.1	Introduction	139
7.2	Rod Elements	139
7.2.1	Truss Element	139
7.2.2	Beam Element	140
7.3	Triangular Elements	141
7.3.1	Cartesian Coordinate System (CST)	141
7.3.2	Natural Coordinate System	142
7.3.2.1	Linear, T3	142
7.3.2.2	Quadratic Element (T6)	143
7.4	Bilinear Rectangular Element	145
7.5	Element Assessment	146

Draft

10.3.3	† Least-Squares Method	192
10.3.4	Galerkin Method	192
E 10-1	String Vibration	193
10.4	Applications of the Galerkin Method to 3D Elasticity Problems	195
10.4.1	Derivation of the Weak Form	195
10.4.2	FE Discretization	197
11	FINITE ELEMENT DISCRETIZATION OF THE FIELD EQUATION	199
11.1	Derivation of the Weak Form	199
11.2	FE Discretization	200
11.2.1	No Convection	201
11.2.2	Convection	201
11.3	Illustrative Examples	202
E 11-1	Composite Wall	202
E 11-2	Heat Transfer across a Fin	205
11.4	Comparison Between Vector and Scalar Formulations	209
12	TOPICS in STRUCTURAL MECHANICS	211
12.1	Condensation/Substructuring	211
12.2	Element Evaluation	212
12.2.1	Patch Test	212
12.2.2	Eigenvalue Test	212
12.2.3	Order of Integration	214
12.2.3.1	Full Integration	214
12.2.3.2	Reduced Integration	214
12.2.3.3	Selective Reduced Integration	216
12.3	Parasitic Shear/Incompatible Elements	216
12.3.1	Q4, The Problem	216
12.3.2	Q6, The Solution	217
12.3.3	QM6, Further Enhancements	218
12.4	Rotational D.O.F.	218
12.5	Constraints	218
13	GEOMETRIC NONLINEARITY	221
13.1	Introduction	221
13.1.1	Strong Form	222
13.1.1.1	Lower Order Differential Equation	222
13.1.1.2	Higher Order Differential Equation	223
13.1.2	Weak Form	225
13.1.2.1	Strain Energy	225
13.1.2.2	Euler Equation	226
13.2	Finite Element Discretization	227
13.3	Elastic Instability; Bifurcation Analysis	228
E 13-1	Column Stability	229
E 13-2	Frame Stability	232
13.4	Second-Order Elastic Analysis; Geometric Non-Linearity	234
E 13-3	Effect of Axial Load on Flexural Deformation	234
E 13-4	Bifurcation	237
13.5	Summary	240

Draft

E 16-1	MATLAB Code for Explicit Time Integration	289
16.3.1.2	NonLinear Systems	290
16.3.2	Implicit Case	290
16.3.2.1	Newmark Method; Forward difference	290
16.3.2.2	Linear Case	292
16.3.2.3	NonLinear Case	293
16.4	Free Vibration	293
16.5	Homework	294
A	VECTOR OPERATIONS	297
A.1	Vector Differentiation	297
A.1.1	Derivative WRT to a Scalar	297
E A-1	Tangent to a Curve	298
A.1.2	Divergence	299
E A-2	Divergence	301
A.1.3	Gradient	302
A.1.4	Scalar	302
E A-3	Gradient of a Scalar	302
E A-4	Stress Vector normal to the Tangent of a Cylinder	303
A.2	Vector Integrals	304
A.2.1	Integral of a Vector	304
A.2.2	Line Integral	305
A.2.3	Integration by Parts	305
A.2.4	Gauss; Divergence Theorem	305
A.2.5	Stoke's Theorem	306
A.2.6	Green; Gradient Theorem	306
E A-5	Physical Interpretation of the Divergence Theorem	306
B	CASE-STUDY: FRACTURING of A DAM DUE TO THERMAL LOAD	309
B.1	INTRODUCTION	309
B.1.1	Elastic and Thermal Properties	309
B.1.2	Loads	309
B.2	ANALYSIS II; "Thermal Shock"	311
B.2.1	Thermal Analysis	311
B.2.2	Stress Analysis	315
B.2.3	Data Files	315
B.3	CONCLUSIONS	315
C	MISC.	319
C.1	Units & Conversion Factors	319
C.2	Metric Prefixes and Multipliers	320

List of Figures

1	Summary of Variational Methods	24
2	Duality of Variational Principles	25
3	Frame Example	28
4	Example for [ID] Matrix Determination	30
5	Simple Frame Analyzed with the MATLAB Code	32
6	34
7	Simple Frame Analyzed with the MATLAB Code	38
8	Stiffness Analysis of one Element Structure	41
1.1	Finite Element Process, (Bathe 1996)	46
1.2	Seepage Problem	47
1.3	One Dimensional Heat Conduction	49
1.4	Rod subjected to Step Load	50
1.5	System of Rigid Carts Interconnected by Linear Springs, (Bathe 1996)	52
1.6	Slab Subjected to Temperature Boundary Conditions, (Bathe 1996)	53
1.7	Pipe Network, (Bathe 1996)	54
1.8	DC Network, (Bathe 1996)	55
1.9	Equivalent Trusses/Direct Stiffness	56
1.10	Heat Transfer Idealization in an Electron Tube, (Bathe 1996)	59
1.11	Stability of a Two Rigid Bars System	61
1.12	Idealization, Discretization and Solution of a Numerical Simulation, (Felippa 2000)	62
2.1	Stresses as Tensor Components	71
2.2	Cauchy's Tetrahedron	72
2.3	Flux Through Area dS	75
2.4	Equilibrium of Stresses, Cartesian Coordinates	77
2.5	Flux vector	83
2.6	Flux Through Sides of Differential Element	85
2.7	*Flow through a surface Γ	85
2.8	Components of Tonti's Diagram, (Felippa 2000)	88
2.9	Fundamental Equations of Solid Mechanics and Heat Flow	89
3.1	Voronoi and Delaunay Tessellation	92
3.2	Control Point for a 2D Mesh	94
3.3	Control Point for a 3D Mesh	94
3.4	A Two Dimensional Triangularization AlgorithmControl Point for a 3D Mesh	95
4.1	Tonti Diagram for the Total Potential Energy, (Červenka, J. 1994)	100
4.2	Tonti Diagram for Hu-Washizu, (Červenka, J. 1994)	107
4.3	Uniformly Loaded Simply Supported Beam Analysed by the Rayleigh-Ritz Method	109
5.1	Axial Finite Element	114
5.2	Constant Strain Triangle Element	116

Draft

14.1	Finite Element Formulation	241
14.2	Stresses in a Plate	242
14.3	Free Body Diagram of an Infinitesimal Plate Element	243
14.4	Displacements in a Plate	244
14.5	Positive Moments and Rotations	245
14.6	Rectangular Plate Element	252
14.7	Triangular Plate Element in Natural Coordinate System	256
14.8	Edges of Adjacent Triangular Elements	258
14.9	Discrete Kirchhoff Triangular Element	259
15.1	Test Controls	264
15.2	Newton-Raphson Method	267
15.3	Modified Newton-Raphson Method, Initial Tangent in Increment	268
15.4	Modified Newton-Raphson Method, Initial Problem Tangent	268
15.5	Incremental Secant, Quasi-Newton Method	269
15.6	Schematic of Line Search, (Reich 1993)	270
15.7	Flowchart for Line Search Algorithm, (Reich 1993)	271
15.8	Divergence of Load-Controlled Algorithms	272
15.9	Hydrostatically Loaded Gravity Dam	274
15.10	Load-Displacement Diagrams with Snapback	274
15.11	Flowchart for an incremental nonlinear finite element program with indirect displacement control	277
15.12	Two points on the load-displacement curve satisfying the arc-length constraint	278
15.13	Flow chart for line search with IDC methods	280
A.1	Differentiation of position vector \mathbf{p}	298
A.2	Curvature of a Curve	298
A.3	Vector Field Crossing a Solid Region	299
A.4	Flux Through Area dA	300
A.5	Infinitesimal Element for the Evaluation of the Divergence	300
A.6	Radial Stress vector in a Cylinder	303
A.7	Gradient of a Vector	304
A.8	Physical Interpretation of the Divergence Theorem	307
B.1	Boundary Description of Dam for Transient Thermal Analysis	311
B.2	Heat of Hydration Interpolations	313
B.3	Temperature Distribution in the Transient Thermal Analysis at Day 8	314
B.4	Maximum Principal Stresses and Deformed Mesh at Day 8	315

List of Tables

1	Summary of Variational Terms Associated with One Dimensional Elements	23
2.1	Selected Examples of Diffusion Problems	83
2.2	Comparison of Scalar and Vector Field Problems	87
2.3	Classification of various Physical Problems, (Kardestuncer 1987)	90
4.1	Functionals in Linear Elasticity	97
4.2	Comparison Between Total Potential Energy and Hu-Washizu Formulations	106
5.1	Characteristics of Beam Element Shape Functions	121
5.2	Interpretation of Shape Functions in Terms of Polynomial Series (1D & 2D)	127
5.3	Polynomial Terms in Various Element Formulations (1D & 2D)	127
7.1	Shape Functions and Derivatives for T6 Element	144
8.1	Shape Functions, and Natural Derivatives for Q8 Element	161
8.2	Shape Functions for Variable Node Elements	164
8.3	Weights for Newton-Cotes Quadrature Formulas	166
8.4	Integration Points and Weights for Gauss-Quadrature Formulae Over the Interval $[-1, 1]$	168
8.5	Coordinates and Weights for Numerical Integration over a Triangle	170
8.6	Natural Coordinates of Bilinear Quadrilateral Nodes	171
9.1	Polynomial orders of the shape functions.	183
9.2	Table of α coefficients and spectral radii for CS technique.	186
11.1	Comparison of Scalar and Vector Field Problems, Revisited	209
12.1	Full and Reduced Numerical Integrations for Quadrilateral Elements	215
12.2	Bilinear and Exact Displacements/Strains	217
14.1	Comparison of Governing Equations in Elasticity and Plate Bending	251
14.2	Integration Rules for Mindlin Plate Elements	255
A.1	Similarities Between Multiplication and Differentiation Operators	297
B.1	Concrete Material Properties	310
B.2	Thermal Properties of the concrete	310
B.3	Interface Element Material Properties	310
B.4	Loads applied on the Dam	310
B.5	Heat of Hydration From the Literature	312
B.6	Heat of Hydration Adopted in the Simulation; Days and J/Kg/Day	314
B.7	Sresses Along the Interface Element; [m] and [Pa]	316
B.8	Crack Opening and Sliding Displacements; [m]	316

Draft

NOTATION

SCALARS	
A	Area
c	Specific heat
E	Elastic Modulus
h	Film coefficient for convection heat transfer
I	Moment of inertia
J	St Venant's torsional constant
L	Length
Q	Rate of internal heat generation per unit volume
t	Time
T	Temperature
u, v, w	Translational displacements along the x, y, and z directions
U_0	Strain energy density
U	Strain energy
U_0^*	Complementary strain energy density
U^*	Complementary strain energy
W	Work
Π	Potential energy
α	Coefficient of thermal expansion
μ	Shear modulus
ν	Poisson's ratio
ρ	mass density
θ	Rotational displacement
δM	Virtual moment
δP	Virtual force
$\delta \theta$	Virtual rotation
δu	Virtual displacement
$\delta \phi$	Virtual curvature
δU	Virtual internal strain energy
δW	Virtual external work

TENSORS order 1

\mathbf{a}	Vector of coefficients in assumed displacement field
\mathbf{b}	Body force
\mathbf{c}	Nodal coordinates
\mathbf{F}	Unknown element forces and unknown support reactions
\mathbf{p}	Matrix of coefficients of a polynomial series
\mathbf{N}	Displacement shape functions
$\tilde{\mathbf{N}}$	Coordinate shape functions
\mathbf{p}	Element nodal forces = \mathbf{F}
\mathbf{P}	Structure nodal forces
\mathbf{q}	Flux per unit area
\mathbf{R}	Structure reactions
\mathcal{R}	Residuals
\mathbf{t}	Traction vector
$\hat{\mathbf{t}}$	Specified tractions along Γ_t
\mathbf{u}	Displacement vector
$\hat{\mathbf{u}}(x)$	Specified displacements along Γ_u
\mathbf{u}	Displacement vector
$\bar{\mathbf{u}}_e$	Nodal element displacements
$\bar{\mathbf{u}}$	Nodal displacements in a continuous system

Draft

ID	Matrix relating nodal dof to structure dof
LM	structure dof of nodes connected to a given element

1	Jan. 16	Introduction; Course objective; Overview; Notation.	
	18	Mathematical Formulations.	
2	23	Elasticity	
	25	Direct Method; Field Eq.	
3	30	Variational Methods	
	Feb. 1	Mesh Generators; Laboratory	
4	6	Variational Methods, Mechanics; Laboratory	
	8	FE Discretization and Requirements; C^0 Elements.	
5	13	Isoparametric Elements, Bar Element	6.1-6.14
	15	Isoparametric Element, Bilinear Element	
6	20	Isoparametric Element; Quadratic, Hierarchical Elements; Numerical integration	
	22	Isoparametric Element; Numerical integration	
7	27	Laboratory	
	29	Weighted Residuals	
8	Mar. 5	Galerkin; 3D Elasticity; Field Equation	
	7	Field Equation, Theory, application	Ch. 16
9	12	Field Equation	
	14	Exam I	
10	19	Lab (Field Equations)	
	21	Error Analysis	
SPRING BREAK			
12	Apr. 2	Topics (Condensation, Transformation, Integration, Test)	
	4	Order of Integration, Eigenvalue tests	
13	9	Plate Bending	9.1-9.6
	11	Plate Bending	11.1-11.5
14	16	Plate Bending	
	18	Geometric Non Linearity	Ch. 14.
15	23	Geometric Nonlinearity	
	25	Material Nonlinearity	Ch. 17
16	30	Dynamics	Ch. 13
	May 2	Review	

Chapter 0

PREREQUISITE

¹ In the first course (CVEN4525/5525, *Finite Element I; Framed Structures*), the direct stiffness method was first introduced (element stiffness matrix, transformation matrix, global stiffness matrix assembly, internal force recovery). As an interlude we then covered the flexibility method and stiffness-flexibility relationship. The second part of the course began with a thorough coverage of variational method (duality between extremization of a functional and a corresponding euler differential equation) followed by a rigorous introduction/derivation of the various energy methods.

0.1 Variational Formulations

² A summary of the various methods introduced in *Finite Element I; Framed Structures* is shown in Fig. 1, Fig. 2, and Table 1.

	U	Virtual Displacement δU		Virtual Force δU^*	
		General	Linear	General	Linear
Axial	$\frac{1}{2} \int_0^L \frac{P^2}{AE} dx$	$\int_0^L \sigma \delta \varepsilon dx$	$\int_0^L \underbrace{E \frac{du}{dx}}_{\sigma} \underbrace{\frac{d(\delta u)}{dx}}_{\delta \varepsilon} \underbrace{A dx}_{d\Omega}$	$\int_0^L \delta \sigma \varepsilon dx$	$\int_0^L \underbrace{\frac{\delta P}{\delta \sigma}}_{\varepsilon} \underbrace{\frac{P}{AE}}_{\varepsilon} dx$
Shear	...	$\int_0^L V \delta \gamma_{xy} dx$...	$\int_0^L \delta V \gamma_{xy} dx$...
Flexure	$\frac{1}{2} \int_0^L \frac{M^2}{EI_z} dx$	$\int_0^L M \delta \phi dx$	$\int_0^L \underbrace{EI_z \frac{d^2 v}{dx^2}}_{\sigma} \underbrace{\frac{d^2(\delta v)}{dx^2}}_{\delta \varepsilon} dx$	$\int_0^L \delta M \phi dx$	$\int_0^L \underbrace{\frac{\delta M}{\delta \sigma}}_{\varepsilon} \underbrace{\frac{M}{EI_z}}_{\varepsilon} dx$
Torsion	$\frac{1}{2} \int_0^L \frac{T^2}{GJ} dx$	$\int_0^L T \delta \theta dx$	$\int_0^L \underbrace{GJ \frac{d\theta_x}{dx}}_{\sigma} \underbrace{\frac{d(\delta \theta_x)}{dx}}_{\delta \varepsilon} dx$	$\int_0^L \delta T \theta dx$	$\int_0^L \underbrace{\frac{\delta T}{\delta \sigma}}_{\varepsilon} \underbrace{\frac{T}{GJ}}_{\varepsilon} dx$
	W	Virtual Displacement δW		Virtual Force δW^*	
P	$\sum_i \frac{1}{2} P_i \Delta_i$	$\sum_i P_i \delta \Delta_i$		$\sum_i \delta P_i \Delta_i$	
M	$\sum_i \frac{1}{2} M_i \theta_i$	$\sum_i M_i \delta \theta_i$		$\sum_i \delta M_i \theta_i$	
w	$\int_0^L w(x)v(x) dx$	$\int_0^L w(x)\delta v(x) dx$		$\int_0^L \delta w(x)v(x) dx$	

Table 1: Summary of Variational Terms Associated with One Dimensional Elements

Draft

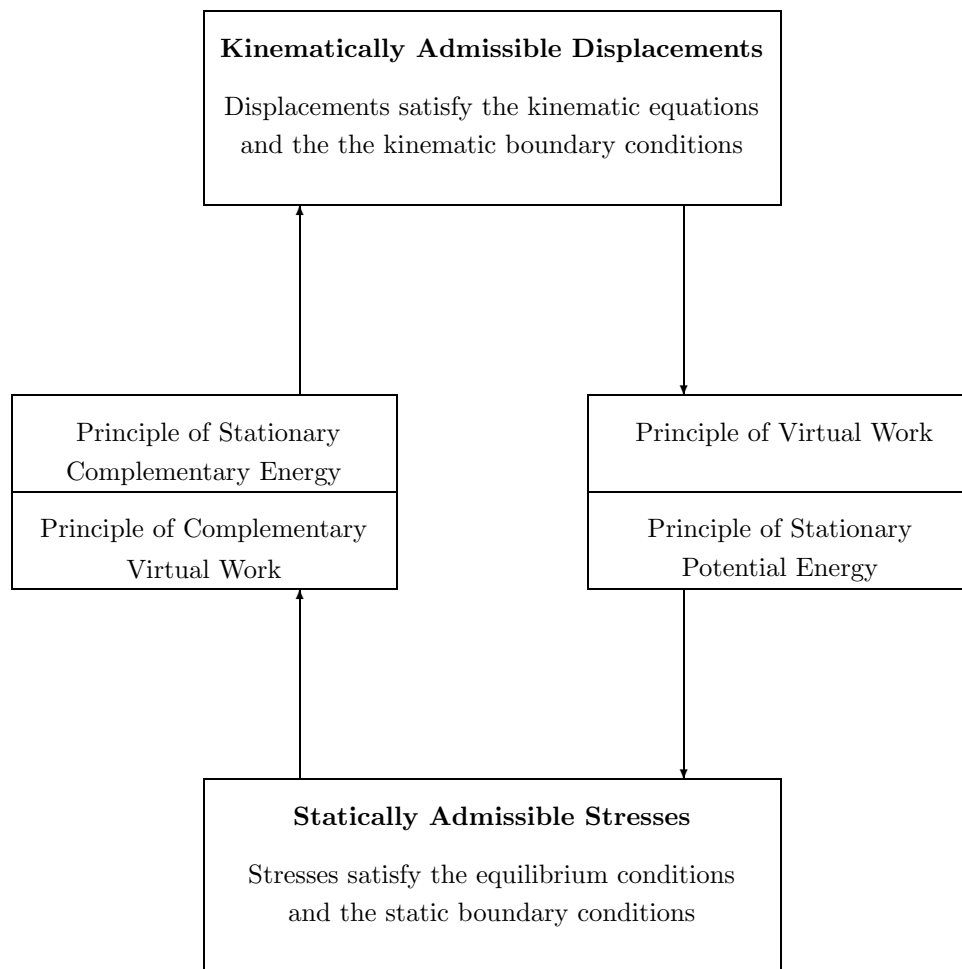

Figure 2: Duality of Variational Principles

0.2.3 Element Stiffness Matrix Formulation

Let us consider the most general case, or element with:

Initial strain: (temperature effect, support settlement, or other) such that:

$$\varepsilon_x = \underbrace{\frac{\sigma_x}{E}}_{\text{due to load}} + \underbrace{\varepsilon_x^i}_{\text{initial strain}} \quad (0.6)$$

thus:

$$\sigma_x = E\varepsilon_x - E\varepsilon_x^i \quad (0.7)$$

or in matrix form:

$$\{\boldsymbol{\sigma}\} = [\mathbf{D}]\{\boldsymbol{\varepsilon}\} - [\mathbf{D}]\{\boldsymbol{\varepsilon}^i\} \quad (0.8)$$

where $[\mathbf{D}]$ is the constitutive matrix which relates stress and strain.

Load: $q(x)$ along it.

Let us apply the principle of virtual work.

$$\delta\bar{U} = \delta\bar{W} \quad (0.9-a)$$

$$\delta\bar{U} = \int_{\text{vol}} [\delta\bar{\boldsymbol{\varepsilon}}]\{\boldsymbol{\sigma}\}d\text{Vol} \quad (0.9-b)$$

$$\{\boldsymbol{\sigma}\} = [\mathbf{D}]\{\boldsymbol{\varepsilon}\} - [\mathbf{D}]\{\boldsymbol{\varepsilon}^i\} \quad (0.9-c)$$

$$\{\delta\bar{\boldsymbol{\varepsilon}}\} = [\mathbf{B}]\{\delta\bar{\boldsymbol{\Delta}}\} \quad (0.9-d)$$

$$\{\boldsymbol{\varepsilon}\} = [\mathbf{B}]\{\boldsymbol{\Delta}\} \quad (0.9-e)$$

$$[\delta\bar{\boldsymbol{\varepsilon}}] = [\delta\bar{\boldsymbol{\Delta}}][\mathbf{B}]^T \quad (0.9-f)$$

$$(0.9-g)$$

Combining Eqns. 0.9-a, 0.9-b, 0.9-c, 0.9-f, and 0.9-e, the internal virtual strain energy is given by:

$$\begin{aligned} \delta\bar{U} &= \int_{\text{vol}} \underbrace{[\delta\bar{\boldsymbol{\Delta}}][\mathbf{B}]^T}_{\text{Virt. Nodal Displ.}} \underbrace{[\mathbf{D}][\mathbf{B}]\{\boldsymbol{\Delta}\}}_{\text{Nodal Force}} d\text{Vol} - \int_{\text{vol}} [\delta\bar{\boldsymbol{\Delta}}][\mathbf{B}]^T [\mathbf{D}]\{\boldsymbol{\varepsilon}^i\}d\text{Vol} \\ &= [\delta\bar{\boldsymbol{\Delta}}] \int_{\text{vol}} [\mathbf{B}]^T [\mathbf{D}][\mathbf{B}] d\text{Vol}\{\boldsymbol{\Delta}\} - [\delta\bar{\boldsymbol{\Delta}}] \int_{\text{vol}} [\mathbf{B}]^T [\mathbf{D}]\{\boldsymbol{\varepsilon}^i\}d\text{Vol} \end{aligned} \quad (0.10-a)$$

the virtual external work in turn is given by:

$$\delta\bar{W} = \underbrace{[\delta\bar{\boldsymbol{\Delta}}]}_{\text{Virt. Nodal Displ.}} \underbrace{\{\mathbf{F}\}}_{\text{Nodal Force}} + \int_l [\delta\bar{\boldsymbol{\Delta}}]q(x)dx \quad (0.11)$$

combining this equation with:

$$\{\delta\bar{\boldsymbol{\Delta}}\} = [\mathbf{N}]\{\delta\bar{\boldsymbol{\Delta}}\} \quad (0.12)$$

yields:

$$\delta\bar{W} = [\delta\bar{\boldsymbol{\Delta}}]\{\mathbf{F}\} + [\delta\bar{\boldsymbol{\Delta}}] \int_0^l [\mathbf{N}]^T q(x) dx \quad (0.13)$$

Equating the internal strain energy Eqn. 0.10-a with the external work Eqn. 0.13, we obtain:

$$\begin{aligned} &[\delta\bar{\boldsymbol{\Delta}}] \underbrace{\int_{\text{vol}} [\mathbf{B}]^T [\mathbf{D}][\mathbf{B}] d\text{Vol}\{\boldsymbol{\Delta}\}}_{[\mathbf{K}]} - [\delta\bar{\boldsymbol{\Delta}}] \underbrace{\int_{\text{vol}} [\mathbf{B}]^T [\mathbf{D}]\{\boldsymbol{\varepsilon}^i\}d\text{Vol}}_{\{\mathbf{F}^{\text{init}}\}} = \\ &[\delta\bar{\boldsymbol{\Delta}}]\{\mathbf{F}\} + [\delta\bar{\boldsymbol{\Delta}}] \underbrace{\int_0^l [\mathbf{N}]^T q(x) dx}_{\{\mathbf{F}^e\}} \end{aligned} \quad (0.14-a)$$

the global (restrained or structure's) stiffness matrix is

$$\mathbf{K} = \begin{bmatrix} K_{11} & K_{12} & K_{13} \\ K_{21} & K_{22} & K_{23} \\ K_{31} & K_{32} & K_{33} \end{bmatrix} \quad (0.19)$$

and the first column corresponds to all the internal forces in the unrestrained d.o.f. when a unit displacement along global d.o.f. 1 is applied.

0.3.1.1 Structural Stiffness Matrix

The structural stiffness matrix is assembled only for those active degrees of freedom which are active (i.e. unrestrained). It is the one which will be inverted (or rather decomposed) to determine the nodal displacements.

0.3.1.2 Augmented Stiffness Matrix

The augmented stiffness matrix is expressed in terms of all the dof. However, it is partitioned into two groups with respective subscript 'u' where the displacements are known (zero otherwise), and t where the loads are known.

$$\left\{ \begin{array}{c} \mathbf{P}_t \\ \mathbf{R}_u \end{array} \right\} = \left[\begin{array}{c|c} \mathbf{K}_{tt} & \mathbf{K}_{tu} \\ \mathbf{K}_{ut} & \mathbf{K}_{uu} \end{array} \right] \left\{ \begin{array}{c} \Delta_t \\ \Delta_u \end{array} \right\} \quad (0.20)$$

We note that \mathbf{K}_{tt} corresponds to the structural stiffness matrix.

The first equation enables the calculation of the unknown displacements.

$$\Delta_t = \mathbf{K}_{tt}^{-1} (\mathbf{P}_t - \mathbf{K}_{tu} \Delta_u) \quad (0.21)$$

The second equation enables the calculation of the reactions

$$\mathbf{R}_u = \mathbf{K}_{ut} \Delta_t + \mathbf{K}_{uu} \Delta_u \quad (0.22)$$

For internal book-keeping purpose, since we are assembling the *augmented* stiffness matrix, we proceed in two stages:

1. First number all the global unrestrained degrees of freedom
2. Then number separately all the global restrained degrees of freedom (i.e. those with known displacements, zero or otherwise) starting with -1 this will enable us later on to distinguish the restrained from unrestrained dof.

The element internal forces (axial and shear forces, and moment at each end of the member) are determined from

$$p_{int}^{(e)} = \mathbf{k}^{(e)} \boldsymbol{\delta}^{(e)} \quad (0.23)$$

at the element level where $p_{int}^{(e)}$ is the six by six array of internal forces, $\mathbf{k}^{(e)}$ the element stiffness matrix in local coordinate systems, and $\boldsymbol{\delta}^{(e)}$ is the vector of nodal displacements in local coordinate system. Note that this last array is obtained by first identifying the displacements in global coordinate system, and then premultiplying it by the transformation matrix to obtain the displacements in local coordinate system.

2. At this stage, the [ID] matrix is equal to:

$$\mathbf{ID} = \begin{bmatrix} 0 & 1 & 0 & 1 \\ 0 & 1 & 0 & 0 \\ 0 & 0 & 0 & 0 \end{bmatrix} \quad (0.25)$$

3. After we determined the equation numbers, we would have:

$$\mathbf{ID} = \begin{bmatrix} 1 & -1 & 5 & -3 \\ 2 & -2 & 6 & 8 \\ 3 & 4 & 7 & 9 \end{bmatrix} \quad (0.26)$$

0.3.2.2 LM Vector

15 The LM vector of a given element gives the global degree of freedom of each one of the element degree of freedom's. For the structure shown in Fig. 4, we would have:

$$\begin{aligned} [\mathbf{LM}] &= [-1 \quad -2 \quad 4 \quad 5 \quad 6 \quad 7] \quad \text{element 1 (2} \rightarrow \text{3)} \\ [\mathbf{LM}] &= [5 \quad 6 \quad 7 \quad 1 \quad 2 \quad 3] \quad \text{element 2 (3} \rightarrow \text{1)} \\ [\mathbf{LM}] &= [1 \quad 2 \quad 3 \quad -3 \quad 8 \quad 9] \quad \text{element 3 (1} \rightarrow \text{4)} \end{aligned}$$

0.3.2.3 Assembly of Global Stiffness Matrix

16 As for the element stiffness matrix, the global stiffness matrix $[\mathbf{K}]$ is such that K_{ij} is the force in degree of freedom i caused by a unit displacement at degree of freedom j .

17 Whereas this relationship was derived from basic analysis at the element level, at the structure level, this term can be obtained from the contribution of the element stiffness matrices $[\mathbf{K}^{(e)}]$ (written in global coordinate system).

18 For each K_{ij} term, we shall add the contribution of all the elements which can connect degree of freedom i to degree of freedom j , assuming that those forces are readily available from the individual element stiffness matrices written in global coordinate system.

19 K_{ij} is non-zero if degree of freedom i and degree of freedom j

1. Are connected by an element.
2. Share a node.
3. Are connected by an element and the corresponding value in the element stiffness matrix in the global coordinate system is zero.

20 There are usually more than one element connected to a dof. Hence, individual element stiffness matrices terms must be added up.

21 Because each term of all the element stiffness matrices must find its position inside the global stiffness matrix $[\mathbf{K}]$, it is found computationally most effective to initialize the global stiffness matrix $[\mathbf{K}^S]_{(NEQA \times NEQA)}$ to zero, and then loop through all the elements, and then through each entry of the respective element stiffness matrix $K_{ij}^{(e)}$.

22 The assignment of the element stiffness matrix term $K_{ij}^{(e)}$ (note that e , i , and j are all known since we are looping on e from 1 to the number of elements, and then looping on the rows and columns of the element stiffness matrix i, j) into the global stiffness matrix K_{kl}^S is made through the LM vector (note that it is k and l which must be determined).

23 Since the global stiffness matrix is also symmetric, we would need to only assemble one side of it, usually the upper one.

The full stiffness matrix of a beam element is given by

$$[\mathbf{k}^e] = \begin{matrix} & v_1 & \theta_1 & v_2 & \theta_2 \\ \begin{matrix} V_1 \\ M_1 \\ V_2 \\ M_2 \end{matrix} & \begin{bmatrix} 12EI/L^3 & 6EI/L^2 & -12EI/L^3 & 6EI/L^2 \\ 6EI/L^2 & 4EI/L & -6EI/L^2 & 2EI/L \\ -12EI/L^3 & -6EI/L^2 & 12EI/L^3 & -6EI/L^2 \\ 6EI/L^2 & 2EI/L & -6EI/L^2 & 4EI/L \end{bmatrix} \end{matrix} \quad (0.56)$$

This matrix is singular, it has a rank 2 and order 4 (as it embodies also 2 rigid body motions).

27 We shall consider 3 different cases, Fig. 8

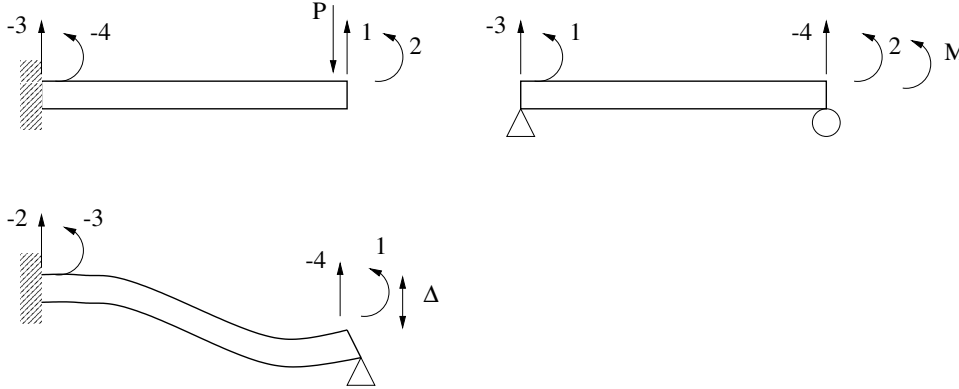

Figure 8: Stiffness Analysis of one Element Structure

Cantilivered Beam/Point Load

1. The *element* stiffness matrix is

$$\mathbf{k} = \begin{matrix} & -3 & -4 & 1 & 2 \\ \begin{matrix} -3 \\ -4 \\ 1 \\ 2 \end{matrix} & \begin{bmatrix} 12EI/L^3 & 6EI/L^2 & -12EI/L^3 & 6EI/L^2 \\ 6EI/L^2 & 4EI/L & -6EI/L^2 & 2EI/L \\ -12EI/L^3 & -6EI/L^2 & 12EI/L^3 & -6EI/L^2 \\ 6EI/L^2 & 2EI/L & -6EI/L^2 & 4EI/L \end{bmatrix} \end{matrix}$$

2. The *structure* stiffness matrix is assembled

$$\mathbf{K} = \begin{matrix} & 1 & 2 & -3 & -4 \\ \begin{matrix} 1 \\ 2 \\ -3 \\ -4 \end{matrix} & \begin{bmatrix} 12EI/L^2 & -6EI/L^2 & -12EI/L^3 & -6EI/L^2 \\ -6EI/L^2 & 4EI/L & 6EI/L^2 & 2EI/L \\ -12EI/L^3 & 6EI/L^2 & 12EI/L^3 & 6EI/L^2 \\ -6EI/L^2 & 2EI/L & 6EI/L^2 & 4EI/L \end{bmatrix} \end{matrix}$$

3. The global matrix can be rewritten as

$$\begin{Bmatrix} -P\sqrt{} \\ 0\sqrt{} \\ R_3? \\ R_4? \end{Bmatrix} = \begin{bmatrix} 12EI/L^2 & -6EI/L^2 & -12EI/L^3 & -6EI/L^2 \\ -6EI/L^2 & 4EI/L & 6EI/L^2 & 2EI/L \\ -12EI/L^3 & 6EI/L^2 & 12EI/L^3 & 6EI/L^2 \\ -6EI/L^2 & 2EI/L & 6EI/L^2 & 4EI/L \end{bmatrix} \begin{Bmatrix} \Delta_1? \\ \theta_2? \\ \Delta_3\sqrt{} \\ \theta_4\sqrt{} \end{Bmatrix}$$

4. \mathbf{K}_{tt} is inverted (or actually decomposed) and stored in the same global matrix

$$\begin{bmatrix} \boxed{L^3/3EI} & \boxed{L^2/2EI} & -12EI/L^3 & -6EI/L^2 \\ \boxed{L^2/2EI} & \boxed{L/EI} & 6EI/L^2 & 2EI/L \\ -12EI/L^3 & 6EI/L^2 & 12EI/L^3 & 6EI/L^2 \\ -6EI/L^2 & 2EI/L & 6EI/L^2 & 4EI/L \end{bmatrix}$$

5. We compute the equivalent load, $\mathbf{P}'_t = \mathbf{P}_t - \mathbf{K}_{tu}\Delta_u$, and overwrite \mathbf{P}_t by \mathbf{P}'_t

$$\begin{aligned} \mathbf{P}_t - \mathbf{K}_{tu}\Delta_u &= \begin{Bmatrix} 0 \\ M \\ 0 \\ 0 \end{Bmatrix} - \begin{bmatrix} L^3/3EI & -L/6EI & 6EI/L^2 & -6EI/L^2 \\ -L/6EI & L/3EI & 6EI/L^2 & -6EI/L^2 \\ 6EI/L^2 & 6EI/L^2 & 12EI/L^3 & -12EI/L^3 \\ -6EI/L^2 & -6EI/L^2 & -12EI/L^3 & 12EI/L^3 \end{bmatrix} \begin{Bmatrix} 0 \\ M \\ 0 \\ 0 \end{Bmatrix} \\ &= \begin{Bmatrix} 0 \\ M \\ 0 \\ 0 \end{Bmatrix} \end{aligned}$$

6. Solve for the displacements, $\Delta_t = \mathbf{K}_{tt}^{-1}\mathbf{P}'_t$, and overwrite \mathbf{P}_t by Δ_t

$$\begin{aligned} \begin{Bmatrix} \theta_1 \\ \theta_2 \\ 0 \\ 0 \end{Bmatrix} &= \begin{bmatrix} L^3/3EI & -L/6EI & 6EI/L^2 & -6EI/L^2 \\ -L/6EI & L/3EI & 6EI/L^2 & -6EI/L^2 \\ 6EI/L^2 & 6EI/L^2 & 12EI/L^3 & -12EI/L^3 \\ -6EI/L^2 & -6EI/L^2 & -12EI/L^3 & 12EI/L^3 \end{bmatrix} \begin{Bmatrix} 0 \\ M \\ 0 \\ 0 \end{Bmatrix} \\ &= \begin{Bmatrix} -ML/6EI \\ ML/3EI \\ 0 \\ 0 \end{Bmatrix} \end{aligned}$$

7. Solve for the reactions, $\mathbf{R}_t = \mathbf{K}_{ut}\Delta_{tt} + \mathbf{K}_{uu}\Delta_u$, and overwrite Δ_u by \mathbf{R}_u

$$\begin{aligned} \begin{Bmatrix} -ML/6EI \\ ML/3EI \\ R_1 \\ R_2 \end{Bmatrix} &= \begin{bmatrix} L^3/3EI & -L/6EI & 6EI/L^2 & -6EI/L^2 \\ -L/6EI & L/3EI & 6EI/L^2 & -6EI/L^2 \\ 6EI/L^2 & 6EI/L^2 & 12EI/L^3 & -12EI/L^3 \\ -6EI/L^2 & -6EI/L^2 & -12EI/L^3 & 12EI/L^3 \end{bmatrix} \begin{Bmatrix} -ML/6EI \\ ML/3EI \\ 0 \\ 0 \end{Bmatrix} \\ &= \begin{Bmatrix} -ML/6EI \\ ML/3EI \\ M/L \\ -M/L \end{Bmatrix} \end{aligned}$$

Cantilevered Beam/Initial Displacement and Concentrated Moment

1. The *element* stiffness matrix is

$$\mathbf{k} = \begin{matrix} & -2 & -3 & -4 & 1 \\ \begin{matrix} -2 \\ -3 \\ -4 \\ 1 \end{matrix} & \begin{bmatrix} 12EI/L^3 & 6EI/L^2 & -12EI/L^3 & 6EI/L^2 \\ 6EI/L^2 & 4EI/L & -6EI/L^2 & 2EI/L \\ -12EI/L^3 & -6EI/L^2 & 12EI/L^3 & -6EI/L^2 \\ 6EI/L^2 & 2EI/L & -6EI/L^2 & 4EI/L \end{bmatrix} \end{matrix}$$

2. The *structure* stiffness matrix is assembled

$$\mathbf{K} = \begin{matrix} & 1 & -2 & -3 & -4 \\ \begin{matrix} 1 \\ -2 \\ -3 \\ -4 \end{matrix} & \begin{bmatrix} 4EI/L & 6EI/L^2 & 2EI/L & -6EI/L^2 \\ 6EI/L^2 & 12EI/L^3 & 6EI/L^2 & -12EI/L^3 \\ 2EI/L & 6EI/L^2 & 4EI/L & -6EI/L^2 \\ -6EI/L^2 & -12EI/L^3 & -6EI/L^2 & 12EI/L^3 \end{bmatrix} \end{matrix}$$

3. The global matrix can be rewritten as

$$\begin{Bmatrix} M\sqrt{} \\ R_2\sqrt{} \\ R_3\sqrt{} \\ R_4\sqrt{} \end{Bmatrix} = \begin{bmatrix} 4EI/L & 6EI/L^2 & 2EI/L & -6EI/L^2 \\ 6EI/L^2 & 12EI/L^3 & 6EI/L^2 & -12EI/L^3 \\ 2EI/L & 6EI/L^2 & 4EI/L & -6EI/L^2 \\ -6EI/L^2 & -12EI/L^3 & -6EI/L^2 & 12EI/L^3 \end{bmatrix} \begin{Bmatrix} \theta_1\sqrt{} \\ \Delta_2\sqrt{} \\ \theta_3\sqrt{} \\ \Delta_4\sqrt{} \end{Bmatrix}$$

4. \mathbf{K}_{tt} is inverted (or actually decomposed) and stored in the same global matrix

$$\begin{bmatrix} L/4EI & 6EI/L^2 & 2EI/L & -6EI/L^2 \\ 6EI/L^2 & 12EI/L^3 & 6EI/L^2 & -12EI/L^3 \\ 2EI/L & 6EI/L^2 & 4EI/L & -6EI/L^2 \\ -6EI/L^2 & -12EI/L^3 & -6EI/L^2 & 12EI/L^3 \end{bmatrix}$$

Chapter 1

INTRODUCTION

1.1 Introduction

¹ Whereas the first course focused exclusively on one dimensional "rod" elements, this course will greatly expand our horizons by considering introducing a methodology to solve partial differential equations, with special emphasis on solid mechanics.

² The field of mechanics, can itself be subdivided into four major disciplines:

Theoretical which deals with the fundamental laws and principles of mechanics. A *Continuum Mechanics* course is a must.

Applied mechanics seeks to apply the theoretical knowledge to engineering applications. *Elasticity* or *Fracture Mechanics* solutions are such an example of applied mechanics.

Computational mechanics combines mathematical models with numerical methods to solve problems on a digital computer.

Experimental mechanics is conducted exclusively in a laboratory through physical measurements.

³ Any problem characterized by a PDE can be analyzed by the finite element method. The process of finite element analysis is illustrated by Fig. 1.12.

1.2 Elliptic, Parabolic and Hyperbolic Equations

⁴ Since the finite element method is a numerical scheme to solve (partial) differential equations, let us closely examine some of the major PDE which can be solved.

⁵ The general form of a partial differential equation is (note that we adopt the tensor notation where $u_{,x} = \frac{du}{dx}$):

$$F(x, y, z, \dots, u, u_{,x}, u_{,y}, u_{,z}, \dots, u_{,xx}, u_{,yy}, \dots, u_{,xy}, u_{,xz}, \dots) = 0$$

and the **order** of the PDE is defined by the order of the highest partial derivatives appearing in the equation. For instance

$$\alpha_1 u_{,xx} + \alpha_2 u_{,xy} + \alpha_3 u_{,yy} + \alpha_4 = 0$$

is quadratic. It would be **linear** if α_i is a function of (x, y) only, otherwise it is **nonlinear**.

⁶ Many significant physical systems can be described by *second order linear partial differential equations*. The most general form is

$$A(x, y) \frac{\partial^2 u}{\partial x^2} + 2B(x, y) \frac{\partial^2 u}{\partial x \partial y} + C(x, y) \frac{\partial^2 u}{\partial y^2} = \phi \left(x, y, u, \frac{\partial u}{\partial x}, \frac{\partial u}{\partial y} \right) \quad (1.1)$$

Draft

Where u is the unknown *state variable*.

7 This equation is classified into three types:

$$\begin{array}{lll}
 B^2 - AC < 0 & \text{Elliptic} & u_{,xx} + u_{,yy} = \begin{cases} G(x, y) & \text{Poisson Equation} \\ 0 & \text{Laplace Equation} \end{cases} \\
 B^2 - AC = 0 & \text{Parabolic} & u_{,xx} = u_{,t} & \text{Heat Equation} \\
 B^2 - AC > 0 & \text{Hyperbolic} & u_{,xx} - u_{,tt} = 0 & \text{Wave Equation}
 \end{array}$$

8 Note:

1. The Laplace equation ($\nabla^2 u = 0$) is a special case of Poisson's equation, where the right hand side is zero. Laplace associated with the **equilibrium** problem.
2. The Heat equation ($Hu_{,t} - K^2 \nabla^2 u = 0$) corresponds to **exponential decay**. Also referred to as **Diffusion equation** (fluid flow through porous media, irrotational fluid flow, Saint Venant torsion of elastic bars...).
3. The Wave equation ($\rho u_{,tt} - K^2 \nabla^2 u = 0$) corresponds to **harmonic motion**

9 This classification is established when solving Eq. 1.1 using the method of characteristics because it is then observed that the character of the solutions is distinctly different for the three categories of equations.

■ **Example 1-1: Seepage Problem;(Bathe 1996)**

The idealized dam shown in Fig. 1.2 stands on permeable soil. Formulate the differential equa-

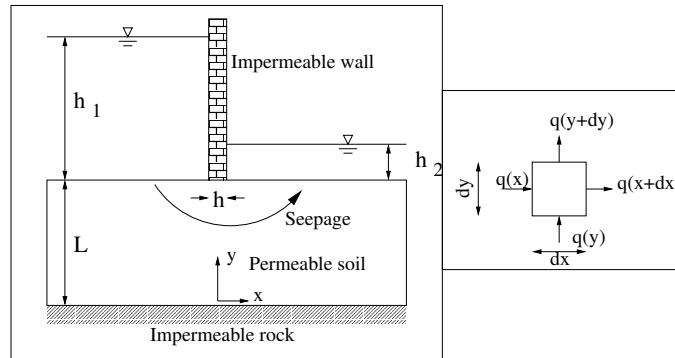

Figure 1.2: Seepage Problem

tion governing the steady-state seepage of water through the soil and give the corresponding boundary conditions.

Solution:

1. For a typical element of widths dx and dy (and unit thickness), the total flow into the element must be equal to the total flow out of the element. Hence we have

$$\left[q_y - \left(q_y + \frac{\partial q_y}{\partial y} \right) \right] dx + \left[q_x - \left(q_x + \frac{\partial q_x}{\partial x} \right) \right] dy = 0 \tag{1.2-a}$$

$$-\frac{\partial q_y}{\partial y} dy dx - \frac{\partial q_x}{\partial x} dx dy = 0 \tag{1.2-b}$$

Draft

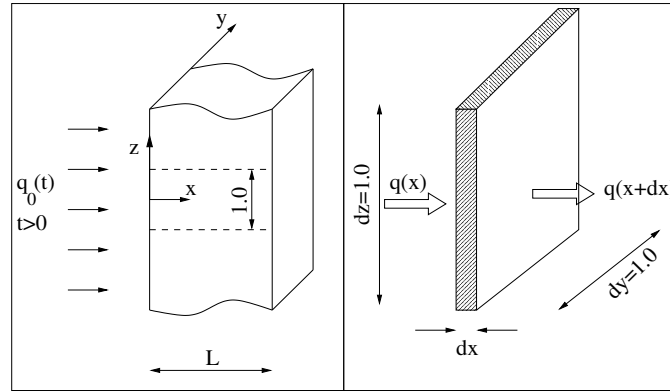

Figure 1.3: One Dimensional Heat Conduction

2. The constitutive relation is given by Fourier's law of heat conduction

$$q = -k \frac{\partial \theta}{\partial x} \quad (1.11)$$

3. Substituting from Eq. 1.11 into Eq. 1.10 we obtain

$$\boxed{k \frac{\partial^2 \theta}{\partial x^2} = \rho c \frac{\partial \theta}{\partial t}} \quad (1.12)$$

In this case the element interconnectivity requirements are contained in the assumption that the temperature θ be a continuous function of x and no additional compatibility conditions are applicable.

4. The boundary conditions are (for $t > 0$)

$$\left. \frac{\partial \theta}{\partial x} \right|_{(0,t)} = -\frac{q_0(t)}{k} \quad (1.13-a)$$

$$\theta|_{(L,t)} = \theta_i \quad (1.13-b)$$

and the initial condition is

$$\theta|_{(x,0)} = \theta_i \quad (1.14)$$

■

■ Example 1-3: Wave Equation, (Bathe 1996)

The rod shown in Fig. 1.4 is initially at rest when a load $F(t)$ is suddenly applied at its free end. Show that the problem-governing differential equation is the **wave equation**

$$\frac{\partial^2 u}{\partial x^2} = \frac{1}{c^2} \frac{\partial^2 u}{\partial t^2}; \quad \text{and} \quad c = \sqrt{\frac{E}{\rho}} \quad (1.15)$$

where E is the Young's modulus, ρ the mass density, and A the cross sectional area, c corresponds to the velocity of sound in the elastic medium, and u is the state variable. Also state the boundary and initial conditions.

Solution:

Seepage Example From the first example we observe

1. The unknown state variables (or their normal derivatives) are given on the boundary. These problems are for this reason also called **boundary value problems**, where we should note that the solution at a general interior point depends on the data at every point of the boundary.
2. A change in only one boundary value affects the complete solution; for instance, the complete solution for ϕ depends on the actual value of h_1 .
3. Elliptic differential equations generally govern the steady-state response of systems.

Diffusion and Wave Propagation Example

1. Comparing the governing differential equations given in the three examples we note that in contrast to the elliptic equation, the parabolic and hyperbolic equations Eq. 1.12 and Eq. 1.18 include time as an independent variable and thus define propagation problems. These problems are also called **initial value problems** because the solution depends on the initial conditions.
2. We may note that analogous to the derivation of the dynamic equilibrium equations of lumped-parameter models, the governing differential equations of propagation problems are obtained from the steady-state equations by including the “resistance to change” (inertia) of the differential elements.
3. The parabolic and hyperbolic differential equations Eq. 1.12 and Eq. 1.18 would become elliptic equations if the time-dependent terms were neglected. In this way the initial value problems would be converted to boundary value problems with steady-state solutions.
4. The solution of a boundary value problem depends on the data at all points of the boundary. However, in propagation problem, the solution at an interior point may depend only on the boundary conditions of part of the boundary and the initial conditions over part of the interior domain.

1.3 Solution of Discrete-System Mathematical models

Section adapted from (Bathe 1996)

¹¹ The essence of the solution of discrete-system is

1. **System idealization:** the actual system is idealized as an assemblage of elements.
2. **Element equilibrium:** the “equilibrium” requirements of each element are established in terms of state variables (displacement, temperature, pressure, etc...).
3. **Element assemblage:** element interconnection requirements are invoked to establish a set of simultaneous equations in terms of the unknown state variables.
4. **Calculation of state variables:** The set of linear equations is solved to determine the state variables at each discretized points.
5. **Calculation of flux variable:** or derived variables.

¹² In the following sections, we shall illustrate, through a number of different physical problems, the solution of discrete-systems. This preliminary exposure is a “snap-shot” of the type of problems which can be addressed by the finite element method.

1.3.1 Steady State Problems

¹³ In this first class of problem, we shall focus on “equilibrium” problems, that is problems where the solution does not change with time.

1.3.1.2 Heat Transfer

15 A wall is constructed of two homogeneous slabs in contact. In steady-state conditions the temperatures in the wall is characterized by the external surface temperature θ_1 and θ_3 and the interface temperature θ_2 . Establish the equilibrium equations of the problem in terms of these temperatures when the ambient temperatures θ_0 and θ_4 are known.

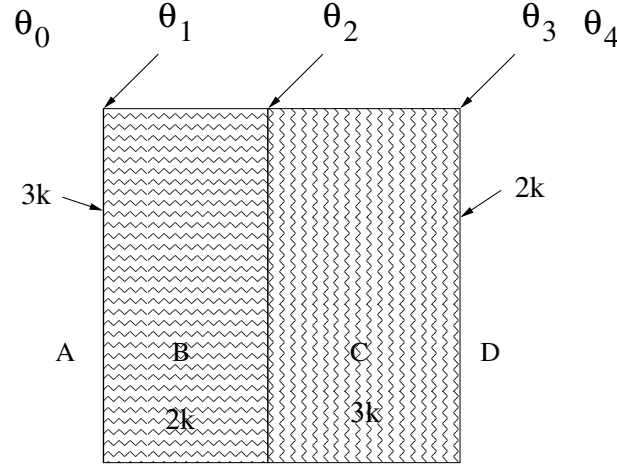

Conductance

Figure 1.6: Slab Subjected to Temperature Boundary Conditions, (Bathe 1996)

1. The governing equation is the heat conduction law

$$q = A\bar{k}\Delta\theta \quad (1.25)$$

where q is the total heat flow, A the area, $\Delta\theta$ the temperature drop in the direction of heat flow, and \bar{k} the conductance or surface coefficient.

2. The state variables are θ_1 , θ_2 and θ_3 .
3. We then apply the “equilibrium” equation for each interface

$$\begin{cases} q_1 = 3k(\theta_0 - \theta_1) & \text{Convection } A \rightarrow B \\ q_2 = 2k(\theta_1 - \theta_2) & \text{Conduction } B \\ q_3 = 3k(\theta_2 - \theta_3) & \text{Conduction } C \\ q_4 = 2k(\theta_3 - \theta_4) & \text{Convection } C \rightarrow D \end{cases} \quad (1.26)$$

4. Heat flow equilibrium must be satisfied

$$q_1 = q_2 = q_3 = q_4 \quad (1.27)$$

thus

$$3k(\theta_0 - \theta_1) = 2k(\theta_1 - \theta_2) \quad (1.28-a)$$

$$2k(\theta_1 - \theta_2) = 3k(\theta_2 - \theta_3) \quad (1.28-b)$$

$$3k(\theta_2 - \theta_3) = 2k(\theta_3 - \theta_4) \quad (1.28-c)$$

5. These equations can be rewritten as

$$\begin{bmatrix} 5k & -2k & 0 \\ -2k & 5k & -3k \\ 0 & -3k & 5k \end{bmatrix} \begin{Bmatrix} \theta_1 \\ \theta_2 \\ \theta_3 \end{Bmatrix} = \begin{Bmatrix} 3k\theta_0 \\ 0 \\ 2k\theta_4 \end{Bmatrix} \quad (1.29)$$

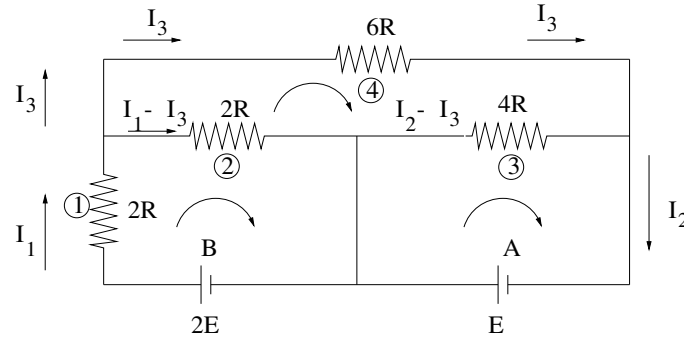

Figure 1.8: DC Network, (Bathe 1996)

1.3.1.4 DC Network

17 Considering the network shown in Fig. 1.8, determine the steady state current distribution in the network.

1. The state variables will be the currents I_1 , I_2 , and I_3 . Ohm's law will be applied

$$\Delta E = \bar{R}I \quad (1.35)$$

where ΔE is the voltage drop across the resistor.

2. The “equilibrium” equation to be satisfied across each element interconnection will be Kirchhoff's law

$$\begin{cases} 2RI_1 + 2R(I_1 - I_3) & = 2E \\ 4R(I_2 - I_3) & = E \\ 6RI_3 + 4R(I_3 - I_2) + 2R(I_3 - I_1) & = 0 \end{cases} \quad (1.36)$$

3. Rewriting this equation in matrix form

$$\begin{bmatrix} 4R & 0 & -2R \\ 0 & 4R & -4R \\ -2R & -4R & 12R \end{bmatrix} \begin{Bmatrix} I_1 \\ I_2 \\ I_3 \end{Bmatrix} = \begin{Bmatrix} 2E \\ E \\ 0 \end{Bmatrix} \quad (1.37)$$

1.3.2 Equivalent “Truss”/Direct Stiffness Models

Each of the preceding problems can be discretized by an “equivalent truss” framework, and the direct stiffness method applied to assemble the global “stiffness” matrix, Fig. 1.9.

Heat Transfer: where the “displacement” correspond to the temperature θ .

1. Element “stiffness” matrices

$$\begin{aligned} \text{Spring 1:} & \quad 3Ku_1 = F_1^{(1)} \\ \text{Spring 2:} & \quad 2K \begin{bmatrix} 1 & -1 \\ -1 & 1 \end{bmatrix} \begin{Bmatrix} u_1 \\ u_2 \end{Bmatrix} = \begin{Bmatrix} F_1^{(1)} \\ F_2^{(2)} \end{Bmatrix} \\ \text{Spring 3:} & \quad 3K \begin{bmatrix} 1 & -1 \\ -1 & 1 \end{bmatrix} \begin{Bmatrix} u_2 \\ u_3 \end{Bmatrix} = \begin{Bmatrix} F_2^{(3)} \\ F_3^{(3)} \end{Bmatrix} \\ \text{Spring 4:} & \quad 2Ku_3 = F_3^{(4)} \end{aligned} \quad (1.38)$$

2. Assemble active degrees of freedom

$$\begin{bmatrix} 2K & -2K & 0 \\ -2K & 2K + 3K & -3K \\ 0 & -3K & 3K \end{bmatrix} \begin{Bmatrix} u_1 \\ u_2 \\ u_3 \end{Bmatrix} = \begin{Bmatrix} F_1^{(2)} \\ F_2^{(2)} + F_2^{(3)} \\ F_3^{(3)} \end{Bmatrix} \quad (1.39)$$

3. Equilibrium at each node

$$\left. \begin{array}{l} F_1^{(1)} + F_1^{(2)} = R_1 \\ F_2^{(2)} + F_2^{(3)} = R_2 \\ F_3^{(3)} + F_3^{(4)} = R_3 \end{array} \right\} \Rightarrow \begin{array}{l} F_1^{(2)} = R_1 - F_1^{(1)} = 3K\theta_0 - 3Ku_1 \\ R_2 = 0 \\ F_3^{(3)} = R_3 - F_3^{(4)} = 2K\theta_4 - 2Ku_3 \end{array} \quad (1.40)$$

4. Rearrange state variables

$$\begin{bmatrix} 5K & -2K & 0 \\ -2K & 5K & -3K \\ 0 & -3K & 5K \end{bmatrix} \begin{Bmatrix} u_1 \\ u_2 \\ u_3 \end{Bmatrix} = \begin{Bmatrix} R_1 \\ R_2 \\ R_3 \end{Bmatrix} = \begin{Bmatrix} 3K\theta_0 \\ 0 \\ 2K\theta_4 \end{Bmatrix} = \quad (1.41)$$

Pipe Network: where the “displacement” correspond to the pressure p

1. Element “stiffness” matrices

$$\begin{array}{l} \text{Spring 1:} \\ \text{Spring 2:} \\ \text{Spring 3:} \\ \text{Spring 4:} \\ \text{Spring 5:} \end{array} \begin{array}{l} \\ \frac{1}{5b} \begin{bmatrix} 1 & -1 \\ -1 & 1 \end{bmatrix} \begin{Bmatrix} u_1 \\ u_2 \end{Bmatrix} = \begin{Bmatrix} F_1^{(2)} \\ F_2^{(2)} \end{Bmatrix} \\ \frac{1}{2b} \begin{bmatrix} 1 & -1 \\ -1 & 1 \end{bmatrix} \begin{Bmatrix} u_2 \\ u_3 \end{Bmatrix} = \begin{Bmatrix} F_3^{(3)} \\ F_4^{(3)} \end{Bmatrix} \\ \frac{1}{3b} \begin{bmatrix} 1 & -1 \\ -1 & 1 \end{bmatrix} \begin{Bmatrix} u_2 \\ u_3 \end{Bmatrix} = \begin{Bmatrix} F_3^{(4)} \\ F_4^{(4)} \end{Bmatrix} \\ \frac{1}{5b} u_3 = F_4^{(5)} \end{array} = \begin{array}{l} F_1^{(1)} \\ \\ \\ \\ F_4^{(5)} \end{array} \quad (1.42)$$

2. Assemble active degrees of freedom

$$\begin{bmatrix} \frac{1}{5b} & -\frac{1}{5b} & 0 \\ -\frac{1}{5b} & \frac{1}{5b} + \frac{1}{2b} + \frac{1}{3b} & -\frac{1}{2b} - \frac{1}{3b} \\ 0 & -\frac{1}{2b} - \frac{1}{3b} & \frac{1}{2b} + \frac{1}{3b} \end{bmatrix} \begin{Bmatrix} u_1 \\ u_2 \\ u_3 \end{Bmatrix} = \begin{Bmatrix} F_1^{(2)} \\ F_3^{(2)} + F_3^{(3)} + F_3^{(4)} \\ F_4^{(3)} + F_4^{(4)} \end{Bmatrix} \quad (1.43)$$

3. Equilibrium at each node

$$\left. \begin{array}{l} F_1^{(1)} + F_1^{(2)} = R_1 \\ F_3^{(2)} + F_3^{(3)} + F_3^{(4)} = R_2 \\ F_4^{(3)} + F_4^{(4)} + F_4^{(5)} = R_3 \end{array} \right\} \Rightarrow \begin{array}{l} F_1^{(2)} = R_1 - F_1^{(1)} = Q - \frac{1}{10b}u_1 \\ R_2 = 0 \\ F_4^{(3)} + F_4^{(4)} = R_3 - F_4^{(5)} = 0 - \frac{1}{5b}u_3 \end{array} \quad (1.44)$$

4. Rearrange state variables and multiply by 30

$$\begin{bmatrix} 9 & -6 & 0 \\ -6 & 31 & -25 \\ 0 & -25 & 31 \end{bmatrix} \begin{Bmatrix} u_1 \\ u_2 \\ u_3 \end{Bmatrix} = \begin{Bmatrix} 30bQ \\ 0 \\ 0 \end{Bmatrix} \quad (1.45)$$

DC Network: where the “displacement” u correspond to the current intensity I

3. The equilibrium equation represents a system of ordinary differential equations of the second order in time. For the solution of these equations it is also necessary to specify the initial conditions for \mathbf{u} and $\dot{\mathbf{u}}$ at time $t = 0$ (\mathbf{u}^0 and $\dot{\mathbf{u}}^0$ respectively).

1.3.3.2 Transient Heat Flow

Fig. 1.10 illustrates an idealization of the heat flow inside an electron tube. A filament is heated to a temperature θ_f by an electric current; heat is convected from the filament to the surrounding gas and is radiated to the wall which also receives heat by convection of the gas. The wall itself convects heat to the surrounding atmosphere, which is at temperature θ_a . It is required to formulate the system-governing heat flow equilibrium equations.

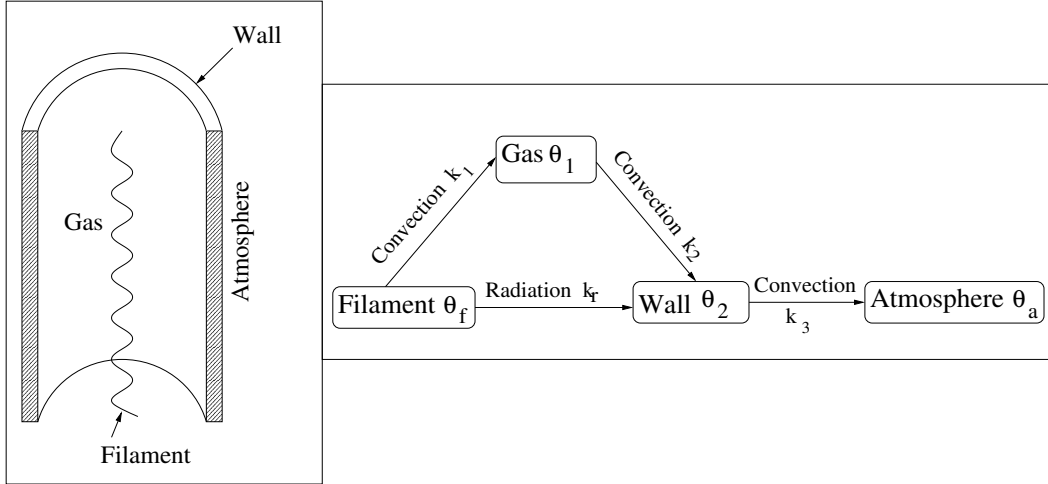

Figure 1.10: Heat Transfer Idealization in an Electron Tube, (Bathe 1996)

1. The state variables are the temperature of the gas, θ_1 , and the temperature of the wall θ_2 .
2. The governing equations for heat transfer are

$$\begin{cases} C_1 \frac{d\theta_1}{dt} = k_1(\theta_f - \theta_1) - k_2(\theta_1 - \theta_2) & \text{Gas} \\ C_2 \frac{d\theta_2}{dt} = k_r [(\theta_f)^4 - (\theta_2)^4] + k_2(\theta_1 - \theta_2) - k_3(\theta_2 - \theta_a) & \text{Wall} \end{cases} \quad (1.54)$$

Note that the first equation is **Newton's law** of cooling, and the second is the **Stefan-Boltzman law** of radiation.

3. The two equations can be written in matrix form as

$$\mathbf{C}\dot{\boldsymbol{\theta}} + \mathbf{K}\boldsymbol{\theta} = \mathbf{Q} \quad (1.55\text{-a})$$

$$\mathbf{C} = \begin{bmatrix} C_1 & 0 \\ 0 & C_2 \end{bmatrix} \quad (1.55\text{-b})$$

$$\mathbf{K} = \begin{bmatrix} (k_1 + k_2) & -k_2 \\ -k_2 & (k_2 + k_3) \end{bmatrix} \quad (1.55\text{-c})$$

$$\boldsymbol{\theta} = \begin{Bmatrix} \theta_1 \\ \theta_2 \end{Bmatrix} \quad (1.55\text{-d})$$

$$\mathbf{Q} = \begin{Bmatrix} k_1\theta_f \\ k_r [(\theta_f)^4 - (\theta_2)^4] + k_3\theta_a \end{Bmatrix} \quad (1.55\text{-e})$$

4. We note that because of the radiation boundary conditions, the heat flow equilibrium equations are nonlinear in $\boldsymbol{\theta}$.

Draft

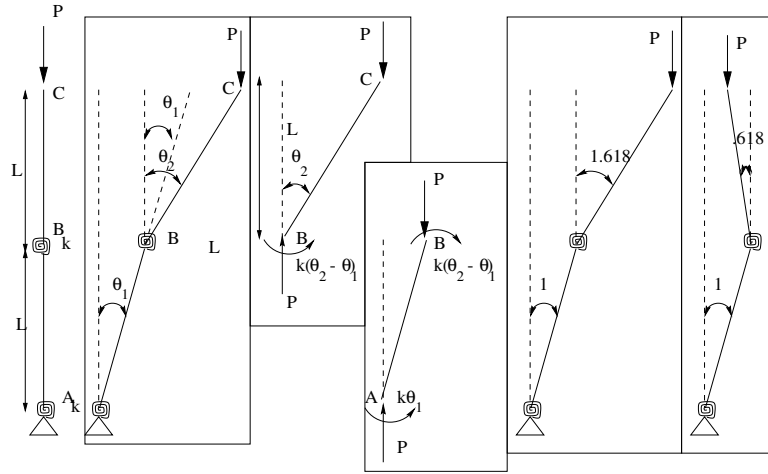

Figure 1.11: Stability of a Two Rigid Bars System

26 Those two equations can be cast in matrix form

$$\begin{bmatrix} 2 & -1 \\ -1 & 1 \end{bmatrix} \begin{Bmatrix} \theta_1 \\ \theta_2 \end{Bmatrix} = \lambda \begin{Bmatrix} \theta_1 \\ \theta_2 \end{Bmatrix} \quad (1.64)$$

where $\lambda = PL/k$, this is an **eigenvalue** formulation and can be rewritten as

$$\begin{bmatrix} 2 - \lambda & -1 \\ -1 & 1 - \lambda \end{bmatrix} \begin{Bmatrix} \theta_1 \\ \theta_2 \end{Bmatrix} = \lambda \begin{Bmatrix} 0 \\ 0 \end{Bmatrix} \quad (1.65-a)$$

$$\begin{vmatrix} 2 - \lambda & -1 \\ -1 & 1 - \lambda \end{vmatrix} = 0 \quad (1.65-b)$$

$$2 - \lambda - 2\lambda + \lambda^2 - 1 = 0 \quad (1.65-c)$$

$$\lambda^2 - 3\lambda + 1 = 0 \quad (1.65-d)$$

$$\lambda_{1,2} = \frac{3 \pm \sqrt{9 - 4}}{2} = \frac{3 \pm \sqrt{5}}{2} \quad (1.65-e)$$

27 Hence we now have two critical loads:

$$\begin{aligned} P_{cr1} &= \frac{3 - \sqrt{5}}{2} \frac{k}{L} = 0.382 \frac{k}{L} \\ P_{cr2} &= \frac{3 + \sqrt{5}}{2} \frac{k}{L} = 2.618 \frac{k}{L} \end{aligned} \quad (1.66)$$

28 We now seek to determine the deformed shape for each of the first critical loads

$$\lambda_1 = \frac{3 - \sqrt{5}}{2} \quad (1.67-a)$$

$$\begin{bmatrix} 2 - \frac{3 - \sqrt{5}}{2} & -1 \\ -1 & 1 - \frac{3 - \sqrt{5}}{2} \end{bmatrix} \begin{Bmatrix} \theta_1 \\ \theta_2 \end{Bmatrix} = \begin{Bmatrix} 0 \\ 0 \end{Bmatrix} \quad (1.67-b)$$

$$\begin{bmatrix} \frac{1 + \sqrt{5}}{2} & -1 \\ -1 & 1 - \frac{-1 + \sqrt{5}}{2} \end{bmatrix} \begin{Bmatrix} \theta_1 \\ \theta_2 \end{Bmatrix} = \begin{Bmatrix} 0 \\ 0 \end{Bmatrix} \quad (1.67-c)$$

$$\begin{bmatrix} 1.618 & -1 \\ -1 & 0.618 \end{bmatrix} \begin{Bmatrix} \theta_1 \\ \theta_2 \end{Bmatrix} = \begin{Bmatrix} 0 \\ 0 \end{Bmatrix} \quad (1.67-d)$$

equations in space and/or time complemented by appropriate boundary conditions. The strong form is numerically solved by the **finite difference FDM** method.

Variational Form, VF: is a functional which must be stationary (maximum or minimum), and which can lead to either the strong form (corresponding Euler equations), or to the weak form. The variational form is solved by the **Rayleigh-Ritz method** which leads to a finite element formulation (FEM).

Weak Form, WF: is a weighted integral equation which "relaxes" the strong form to be satisfied on an average sense inside a finite element through the **Weighted Residual method**.

³² Note that:

1. The variational method provides a relatively easy way to construct the system of governing equations. This ease stems from the fact that in the variational formulation scalar quantities (energies, potentials and so on) are considered rather than vector quantities (forces, displacements, etc.).
2. Not all problems can be solved by the VF, whereas most can be solved by the WF.
3. In complex problems, a combination of techniques is used
 - Fluid-structure interaction: FEM for the structure, FDM for the fluid.
 - Structural dynamics: FEM in space, and FDM in time.

1.4.1 Euler Equation

³³ Given a functional

$$\Pi(u) = \int_a^b F(x, u, u') dx \quad (1.71)$$

it can be shown that its corresponding Euler equation is given by

$$\frac{\partial F}{\partial u} - \frac{d}{dx} \frac{\partial F}{\partial u'} = 0 \quad \text{in } a < x < b \quad (1.72)$$

This differential equation is called the **Euler equation** associated with Π and is a necessary condition for $u(x)$ to extremize Π .

³⁴ Generalizing for a functional Π which depends on two field variables, $u = u(x, y)$ and $v = v(x, y)$

$$\Pi = \int \int F(x, y, u, v, u_x, u_y, v_x, v_y, \dots, v_{,yy}) dx dy \quad (1.73)$$

There would be as many Euler equations as dependent field variables

$$\begin{cases} \frac{\partial F}{\partial u} - \frac{\partial}{\partial x} \frac{\partial F}{\partial u_x} - \frac{\partial}{\partial y} \frac{\partial F}{\partial u_y} + \frac{\partial^2}{\partial x^2} \frac{\partial F}{\partial u_{,xx}} + \frac{\partial^2}{\partial x \partial y} \frac{\partial F}{\partial u_{,xy}} + \frac{\partial^2}{\partial y^2} \frac{\partial F}{\partial u_{,yy}} = 0 \\ \frac{\partial F}{\partial v} - \frac{\partial}{\partial x} \frac{\partial F}{\partial v_x} - \frac{\partial}{\partial y} \frac{\partial F}{\partial v_y} + \frac{\partial^2}{\partial x^2} \frac{\partial F}{\partial v_{,xx}} + \frac{\partial^2}{\partial x \partial y} \frac{\partial F}{\partial v_{,xy}} + \frac{\partial^2}{\partial y^2} \frac{\partial F}{\partial v_{,yy}} = 0 \end{cases} \quad (1.74)$$

■ Example 1-4: Flexure of a Beam

The total potential energy of a beam supporting a uniform load p is given by

$$\Pi = \int_0^L \left(\frac{1}{2} M \kappa - pw \right) dx = \int_0^L \underbrace{\left(\frac{1}{2} (EI w'') w'' - pw \right)}_F dx \quad (1.75)$$

Solution:

Draft

³⁶ Major finite element codes

NASTRAN Originally developed by NASA, primarily used by NASA and its contractors. Original version public domain, later version (McNeal Schwindler) commercial.

SAP Originally developed by Ed. Wilson at Berkeley. First version public domain, later ones available only for PC (SAP90). NONSAP is the nonlinear version of SAP

ANSYS Commercial program mostly used in the Nuclear industry.

ABAQUS Probably the most modern and widely used commercial finite element. (Available in Bechtel Lab).

ALGOR Very widely used PC/based code, mechanical/civil applications.

FEAP Public domain code listed in Zienkiewicz et al., often used in academia as a base for extension.

MERLIN our very own!.

1.6 Examples of applications

1. Aircraft, automobile, submarine
2. Dam, buildings, bridges
3. Mechanical design and optimization
4. Heat transfer
5. Biomechanics (hip joints)
6. Electrical (design of rotors)
7. Coastal engineering
8. Fluid mechanics
9. Coupled problems

Chapter 2

FUNDAMENTAL RELATIONS

2.1 Introduction

¹ Whereas, ideally, a course in *Continuum Mechanics* should be taken prior to a finite element course, this is seldom the case. Most often, students have had a graduate course in *Advanced Strength of Materials*, which can only provide limited background to a solid finite element course.

² Accordingly, this preliminary chapter (mostly extracted from the author's lecture notes in Continuum Mechanics) will partially remedy for occasional deficiencies and will be often referenced.

³ It should be noted that most, but not all, of the material in this chapter will be subsequently referenced.

2.1.1 Notation

⁴ Different set of notations are commonly used in Engineering:

Matrix: Finite Element $[A]$, $[\sigma]$, $\{F\}$

Indicial: Mechanics cartesian, F_x , σ_{ij} , C_{ijkl}

Tensorial: Mechanics cartesian/curvilinear, \mathbf{F} , $\boldsymbol{\sigma}$, \mathbf{C}

Engineering: (Timoshenko/Voigt) Elasticity, σ_x , γ_{xy}

$$\underbrace{\mathbf{x} \cdot \mathbf{A} \cdot \mathbf{x}}_{\text{tensor}} = \underbrace{\mathbf{x}^T \mathbf{A} \mathbf{x}}_{\text{matrix}} = \underbrace{x_i A_{ij} x_j}_{\text{indicial}} \quad (2.1)$$

In the following sections, we shall briefly explain the last two.

2.1.1.1 Indicial Notation

⁵ Whereas the Engineering notation may be the simplest and most intuitive one, it often leads to long and repetitive equations. Alternatively, the tensor will lead to shorter and more compact forms.

⁶ While working on general relativity, Einstein got tired of writing the summation symbol with its range of summation below and above (such as $\sum_{i=1}^{n=3} a_{ij} b_i$) and noted that most of the time the upper range (n) was equal to the dimension of space (3 for us, 4 for him), and that when the summation involved a product of two terms, the summation was over a repeated index (i in our example). Hence, he decided that there is no need to include the summation sign \sum if there was repeated indices (i), and thus any repeated index is a **dummy index** and is summed over the range 1 to 3. An index that is not repeated is called **free index** and assumed to take a value from 1 to 3.

2.1.1.3 Voigt Notation

¹³ In finite element, symmetric second-order tensors are often written as column matrices. This conversion, and the one of other higher-order tensors into column matrices are called **Voigt notation**.

¹⁴ The Voigt rule depends on whether the tensor is a kinetic quantity (such as stress) or a kinematic one (such as strain).

$$\boldsymbol{\sigma} \equiv \begin{bmatrix} \sigma_{11} & \sigma_{12} \\ \sigma_{21} & \sigma_{22} \end{bmatrix} \rightarrow \begin{Bmatrix} \sigma_{11} \\ \sigma_{22} \\ \sigma_{12} \end{Bmatrix} = \begin{Bmatrix} \sigma_1 \\ \sigma_2 \\ \sigma_3 \end{Bmatrix} = \{\boldsymbol{\sigma}\} \quad (2.9-a)$$

$$\boldsymbol{\varepsilon} \equiv \begin{bmatrix} \varepsilon_{11} & \varepsilon_{12} \\ \varepsilon_{21} & \varepsilon_{22} \end{bmatrix} \rightarrow \begin{Bmatrix} \varepsilon_{11} \\ \varepsilon_{22} \\ 2\varepsilon_{12} \end{Bmatrix} = \begin{Bmatrix} \varepsilon_1 \\ \varepsilon_2 \\ \varepsilon_3 \end{Bmatrix} = \{\boldsymbol{\varepsilon}\} \quad (2.9-b)$$

2.1.2 Tensors

¹⁵ We generalize the concept of a vector by introducing the **tensor** (\mathbf{T}), which essentially *exists to operate on vectors \mathbf{v} to produce other vectors* (or on tensors to produce other tensors!). We designate this operation by $\mathbf{T} \cdot \mathbf{v}$ or simply $\mathbf{T}\mathbf{v}$.

¹⁶ We hereby adopt the **tensor** (or dyadic) notation for tensors as **linear vector operators**

$$\mathbf{u} = \mathbf{T} \cdot \mathbf{v} \text{ or } u_i = T_{ij}v_j \quad (2.10-a)$$

$$\mathbf{u} = \mathbf{v} \cdot \mathbf{S} \text{ where } \mathbf{S} = \mathbf{T}^T \quad (2.10-b)$$

¹⁷ Whereas a tensor is essentially an operator on vectors (or other tensors), it is also a physical quantity, independent of any particular coordinate system yet specified most conveniently by referring to an appropriate system of coordinates.

¹⁸ Tensors frequently arise as physical entities whose components are the coefficients of a linear relationship between vectors.

¹⁹ A tensor is classified by the **rank** or **order**. A Tensor of order zero is specified in any coordinate system by one coordinate and is a scalar. A tensor of order one has three coordinate components in space, hence it is a vector. In general 3-D space the number of components of a tensor is 3^n where n is the order of the tensor.

²⁰ A force and a stress are tensors of order 1 and 2 respectively.

²¹ The **sum** of two (second order) tensors is simply defined as:

$$\mathbf{S}_{ij} = \mathbf{T}_{ij} + \mathbf{U}_{ij} \quad (2.11)$$

²² The **multiplication** of a (second order) tensor by a scalar is defined by:

$$\mathbf{S}_{ij} = \lambda \mathbf{T}_{ij} \quad (2.12)$$

²³ In a **contraction**, we make two of the indices equal (or in a mixed tensor, we make a subscript equal to the superscript), thus producing a tensor of order two less than that to which it is applied. For example:

$$\begin{aligned} T_{ij} &\rightarrow T_{ii}; & 2 &\rightarrow 0 \\ u_i v_j &\rightarrow u_i v_i; & 2 &\rightarrow 0 \\ A_{..sn}^{mr} &\rightarrow A_{..sm}^{mr} = B_{.s}^r; & 4 &\rightarrow 2 \\ E_{ij} a_k &\rightarrow E_{ij} a_i = c_j; & 3 &\rightarrow 1 \\ A_{qs}^{mpr} &\rightarrow A_{qr}^{mpr} = B_q^{mp}; & 5 &\rightarrow 3 \end{aligned} \quad (2.13)$$

Draft

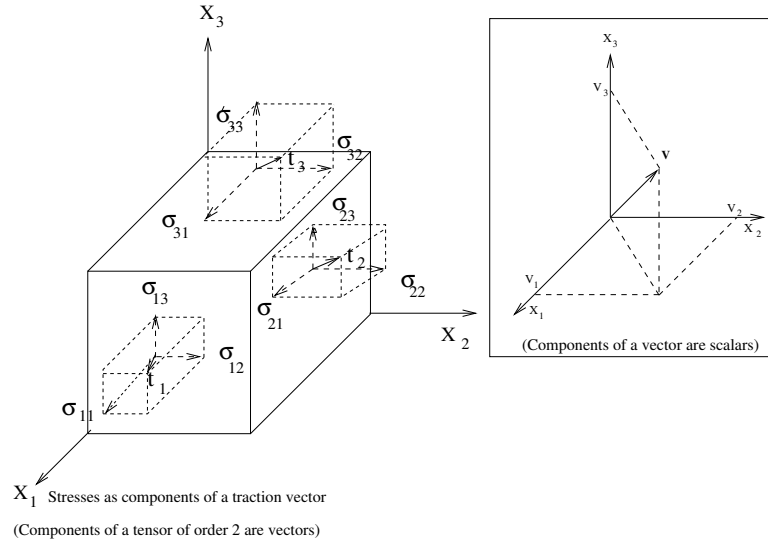

Figure 2.1: Stresses as Tensor Components

³¹ In fact the nine rectangular components σ_{ij} of σ turn out to be the three sets of three vector components $(\sigma_{11}, \sigma_{12}, \sigma_{13})$, $(\sigma_{21}, \sigma_{22}, \sigma_{23})$, $(\sigma_{31}, \sigma_{32}, \sigma_{33})$ which correspond to the three tractions $\mathbf{t}_1, \mathbf{t}_2$ and \mathbf{t}_3 which are acting on the x_1, x_2 and x_3 faces (It should be noted that those tractions are not necessarily normal to the faces, and they can be decomposed into a normal and shear traction if need be). In other words, stresses are nothing else than the components of tractions (stress vector), Fig. 2.1.

³² The state of stress at a point cannot be specified entirely by a single vector with three components; it requires the second-order tensor with all nine components.

2.2.1.2 Traction on an Arbitrary Plane; Cauchy's Stress Tensor

³³ Let us now consider the problem of determining the traction acting on the surface of an oblique plane (characterized by its normal \mathbf{n}) in terms of the known tractions normal to the three principal axis, $\mathbf{t}_1, \mathbf{t}_2$ and \mathbf{t}_3 . This will be done through the so-called Cauchy's tetrahedron shown in Fig. 2.2, and will be obtained without any assumption of equilibrium and it will apply in fluid dynamics as well as in solid mechanics.

³⁴ This equation is a vector equation, and the corresponding algebraic equations for the components of \mathbf{t}_n are

$t_{n_1} = \sigma_{11}n_1 + \sigma_{21}n_2 + \sigma_{31}n_3$	(2.19)
$t_{n_2} = \sigma_{12}n_1 + \sigma_{22}n_2 + \sigma_{32}n_3$	
$t_{n_3} = \sigma_{13}n_1 + \sigma_{23}n_2 + \sigma_{33}n_3$	
Indicial notation $t_{n_i} = \sigma_{ji}n_j$	
Tensor notation $\mathbf{t}_n = \mathbf{n} \cdot \boldsymbol{\sigma} = \boldsymbol{\sigma}^T \cdot \mathbf{n}$	

³⁵ We have thus established that the nine components σ_{ij} are components of the second order tensor, **Cauchy's stress tensor**.

■ Example 2-1: Stress Vectors

Spatial Coordinates (x_1, x_2, x_3) defined in the deformed coordinate system. This gives rise to the **Eulerian coordinate system**

1. If both the displacement gradients and the displacements themselves are small, then $\frac{\partial u_i}{\partial X_j} \approx \frac{\partial u_i}{\partial x_j}$ and thus the Eulerian and the Lagrangian infinitesimal strain tensors may be taken as equal $E_{ij} = E_{ij}^*$.
2. If the displacement gradients are small, but the displacements are large, we should use the Eulerian infinitesimal representation.
3. If the displacements gradients are large, but the displacements are small, use the Lagrangian finite strain representation.
4. If both the displacement gradients and the displacements are large, use the Eulerian finite strain representation.

³⁷ The Lagrangian finite strain tensor can be written as

$$E_{ij} = \frac{1}{2} \left(\frac{\partial u_i}{\partial X_j} + \frac{\partial u_j}{\partial X_i} + \frac{\partial u_k}{\partial X_i} \frac{\partial u_k}{\partial X_j} \right) \quad \text{or} \quad \mathbf{E} = \frac{1}{2} \left(\underbrace{\mathbf{u} \nabla_{\mathbf{X}} + \nabla_{\mathbf{X}} \mathbf{u}}_{\mathbf{J} + \mathbf{J}_c} + \underbrace{\nabla_{\mathbf{X}} \mathbf{u} \cdot \mathbf{u} \nabla_{\mathbf{X}}}_{\mathbf{J}_c \cdot \mathbf{J}} \right) \quad (2.24)$$

or:

$$E_{11} = \frac{\partial u_1}{\partial X_1} + \frac{1}{2} \left[\left(\frac{\partial u_1}{\partial X_1} \right)^2 + \left(\frac{\partial u_2}{\partial X_1} \right)^2 + \left(\frac{\partial u_3}{\partial X_1} \right)^2 \right] \quad (2.25-a)$$

$$E_{12} = \frac{1}{2} \left(\frac{\partial u_1}{\partial X_2} + \frac{\partial u_2}{\partial X_1} \right) + \frac{1}{2} \left[\frac{\partial u_1}{\partial X_1} \frac{\partial u_1}{\partial X_2} + \frac{\partial u_2}{\partial X_1} \frac{\partial u_2}{\partial X_2} + \frac{\partial u_3}{\partial X_1} \frac{\partial u_3}{\partial X_2} \right] \quad (2.25-b)$$

$$\dots = \dots \quad (2.25-c)$$

³⁸ If large deformation is accounted for (such as in buckling), the Eulerian finite strains are:

$$\begin{aligned} \varepsilon_{xx} &= \frac{\partial u}{\partial x} + \frac{1}{2} \left[\left(\frac{\partial u}{\partial x} \right)^2 + \left(\frac{\partial v}{\partial x} \right)^2 + \left(\frac{\partial w}{\partial x} \right)^2 \right] \\ \varepsilon_{yy} &= \frac{\partial v}{\partial y} + \frac{1}{2} \left[\left(\frac{\partial u}{\partial y} \right)^2 + \left(\frac{\partial v}{\partial y} \right)^2 + \left(\frac{\partial w}{\partial y} \right)^2 \right] \\ \varepsilon_{zz} &= \frac{\partial w}{\partial z} + \frac{1}{2} \left[\left(\frac{\partial u}{\partial z} \right)^2 + \left(\frac{\partial v}{\partial z} \right)^2 + \left(\frac{\partial w}{\partial z} \right)^2 \right] \\ \varepsilon_{xy} &= \frac{1}{2} \left(\frac{\partial v}{\partial x} + \frac{\partial u}{\partial y} + \frac{\partial u}{\partial x} \frac{\partial u}{\partial y} + \frac{\partial v}{\partial x} \frac{\partial v}{\partial y} + \frac{\partial w}{\partial x} \frac{\partial w}{\partial y} \right) \\ \varepsilon_{xz} &= \frac{1}{2} \left(\frac{\partial w}{\partial x} + \frac{\partial u}{\partial z} + \frac{\partial u}{\partial x} \frac{\partial u}{\partial z} + \frac{\partial v}{\partial x} \frac{\partial v}{\partial z} + \frac{\partial w}{\partial x} \frac{\partial w}{\partial z} \right) \\ \varepsilon_{yz} &= \frac{1}{2} \left(\frac{\partial w}{\partial y} + \frac{\partial v}{\partial z} + \frac{\partial u}{\partial y} \frac{\partial u}{\partial z} + \frac{\partial v}{\partial y} \frac{\partial v}{\partial z} + \frac{\partial w}{\partial y} \frac{\partial w}{\partial z} \right) \end{aligned} \quad (2.26)$$

or

$$\varepsilon_{ij} = \frac{1}{2} (u_{i,j} + u_{j,i} + u_{k,i} u_{k,j}) \quad (2.27)$$

From this equation, we note that:

1. We define the **engineering shear strain** as

$$\gamma_{ij} = 2\varepsilon_{ij} \quad (i \neq j) \quad (2.28)$$

2. If the strains are given, then these strain-displacements provide a system of (6) nonlinear partial differential equation in terms of the unknown displacements (3).

Draft

⁴³ **Conservation laws** constitute a fundamental component of classical physics. A conservation law establishes a balance of a scalar or tensorial quantity in volume V bounded by a surface S . In its most general form, such a law may be expressed as

$$\underbrace{\frac{d}{dt} \int_V \mathcal{A} dV}_{\text{Rate of variation}} + \underbrace{\int_S \boldsymbol{\alpha} dS}_{\text{Exchange by Diffusion}} = \underbrace{\int_V \mathbf{A} dV}_{\text{Source}} \quad (2.33)$$

where \mathcal{A} is the volumetric density of the quantity of interest (mass, linear momentum, energy, ...) \mathbf{a} , \mathbf{A} is the rate of volumetric density of what is provided from the outside, and $\boldsymbol{\alpha}$ is the rate of surface density of what is lost through the surface S of V and will be a function of the normal to the surface \mathbf{n} .

⁴⁴ Hence, we read the previous equation as: The input quantity (provided by the right hand side) is equal to what is lost across the boundary, and to modify \mathcal{A} which is the quantity of interest. The dimensions of various quantities are given by

$$\dim(\mathbf{a}) = \dim(\mathcal{A}L^{-3}) \quad (2.34\text{-a})$$

$$\dim(\boldsymbol{\alpha}) = \dim(\mathcal{A}L^{-2}t^{-1}) \quad (2.34\text{-b})$$

$$\dim(\mathbf{A}) = \dim(\mathcal{A}L^{-3}t^{-1}) \quad (2.34\text{-c})$$

⁴⁵ Hence this section will apply the previous conservation law to mass, momentum, and energy. The resulting differential equations will provide additional interesting relation with regard to the incompressibility of solids (important in classical hydrodynamics and plasticity theories), equilibrium and symmetry of the stress tensor, and the first law of thermodynamics.

⁴⁶ The enunciation of the preceding three conservation laws plus the second law of thermodynamics, constitute what is commonly known as the **fundamental laws of continuum mechanics**.

⁴⁷ Prior to the enunciation of the first conservation law, we need to define the concept of **flux** across a bounding surface.

⁴⁸ The **flux** across a surface can be graphically defined through the consideration of an imaginary surface fixed in space with continuous “medium” flowing through it. If we assign a positive side to the surface, and take \mathbf{n} in the positive sense, then the volume of “material” flowing through the infinitesimal surface area dS in time dt is equal to the volume of the cylinder with base dS and slant height $v dt$ parallel to the velocity vector \mathbf{v} , Fig. 2.3 (If $\mathbf{v} \cdot \mathbf{n}$ is negative, then the flow is in the negative direction). Hence, we

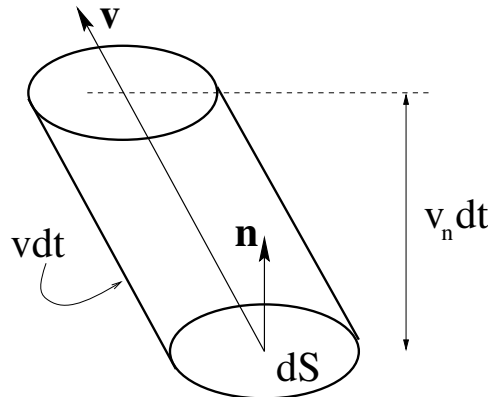

Figure 2.3: Flux Through Area dS

Draft

or for an arbitrary volume

$$\boxed{\frac{\partial T_{ij}}{\partial x_j} + \rho b_i = \rho \frac{dv_i}{dt} \text{ or } \nabla \mathbf{T} + \rho \mathbf{b} = \rho \frac{d\mathbf{v}}{dt}} \quad (2.41)$$

which is **Cauchy's (first) equation of motion**, or **the linear momentum principle**, or more simply **equilibrium equation**.

⁵² When expanded in 3D, this equation yields:

$$\begin{aligned} \frac{\partial T_{11}}{\partial x_1} + \frac{\partial T_{12}}{\partial x_2} + \frac{\partial T_{13}}{\partial x_3} + \rho b_1 &= 0 \\ \frac{\partial T_{21}}{\partial x_1} + \frac{\partial T_{22}}{\partial x_2} + \frac{\partial T_{23}}{\partial x_3} + \rho b_2 &= 0 \\ \frac{\partial T_{31}}{\partial x_1} + \frac{\partial T_{32}}{\partial x_2} + \frac{\partial T_{33}}{\partial x_3} + \rho b_3 &= 0 \end{aligned} \quad (2.42-a)$$

⁵³ We note that these equations could also have been derived from the free body diagram shown in Fig. 2.4 with the assumption of **equilibrium** (via Newton's second law) considering an infinitesimal element of dimensions $dx_1 \times dx_2 \times dx_3$. Writing the summation of forces, will yield

$$\boxed{T_{ij,j} + \rho b_i = 0} \quad (2.43)$$

where ρ is the density, b_i is the body force (including inertia).

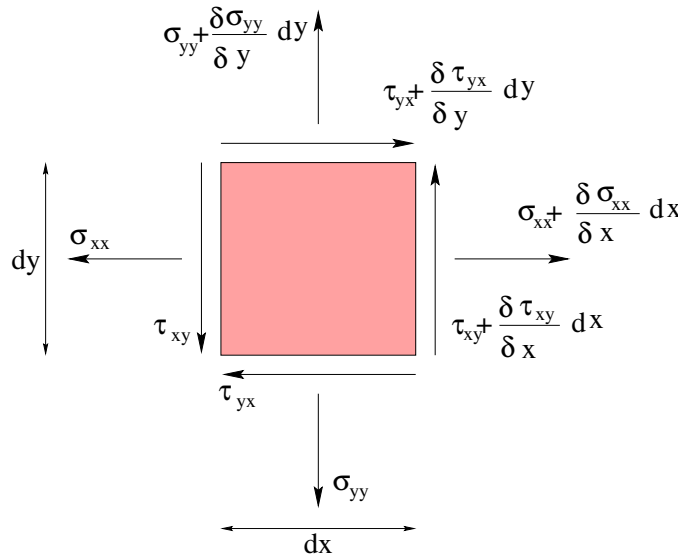

Figure 2.4: Equilibrium of Stresses, Cartesian Coordinates

2.2.3.3 Conservation of Energy; First Principle of Thermodynamics

⁵⁴ The first principle of thermodynamics relates the work done on a (closed) system and the heat transfer into the system to the change in energy of the system. We shall assume that the only energy transfers

61 In terms of Lamé's constants, **Hooke's Law** for an isotropic body is written as

$$\boxed{\begin{array}{l} T_{ij} = \lambda \delta_{ij} E_{kk} + 2\mu E_{ij} \quad \text{or} \quad \mathbf{T} = \lambda \mathbf{I}_E + 2\mu \mathbf{E} \\ E_{ij} = \frac{1}{2\mu} \left(T_{ij} - \frac{\lambda}{3\lambda+2\mu} \delta_{ij} T_{kk} \right) \quad \text{or} \quad \mathbf{E} = \frac{-\lambda}{2\mu(3\lambda+2\mu)} \mathbf{I}_T + \frac{1}{2\mu} \mathbf{T} \end{array}} \quad (2.49)$$

62 In terms of engineering constants:

$$\boxed{\begin{array}{l} \frac{1}{E} = \frac{\lambda+\mu}{\mu(3\lambda+2\mu)}; \nu = \frac{\lambda}{2(\lambda+\mu)} \\ \lambda = \frac{\nu E}{(1+\nu)(1-2\nu)}; \mu = G = \frac{E}{2(1+\nu)} \end{array}} \quad (2.50)$$

63 Similarly in the case of pure shear in the x_1x_3 and x_2x_3 planes, we have

$$\sigma_{21} = \sigma_{12} = \tau \quad \text{all other } \sigma_{ij} = 0 \quad (2.51-a)$$

$$2\varepsilon_{12} = \frac{\tau}{G} \quad (2.51-b)$$

and the μ is equal to the **shear modulus** G .

64 Hooke's law for isotropic material in terms of engineering constants becomes

$$\boxed{\begin{array}{l} \sigma_{ij} = \frac{E}{1+\nu} \left(\varepsilon_{ij} + \frac{\nu}{1-2\nu} \delta_{ij} \varepsilon_{kk} \right) \quad \text{or} \quad \boldsymbol{\sigma} = \frac{E}{1+\nu} \left(\boldsymbol{\varepsilon} + \frac{\nu}{1-2\nu} \mathbf{I}_\varepsilon \right) \\ \varepsilon_{ij} = \frac{1+\nu}{E} \sigma_{ij} - \frac{\nu}{E} \delta_{ij} \sigma_{kk} \quad \text{or} \quad \boldsymbol{\varepsilon} = \frac{1+\nu}{E} \boldsymbol{\sigma} - \frac{\nu}{E} \mathbf{I}_\sigma \end{array}} \quad (2.52)$$

65 When the strain equation is expanded in 3D cartesian coordinates it would yield:

$$\left\{ \begin{array}{l} \varepsilon_{xx} \\ \varepsilon_{yy} \\ \varepsilon_{zz} \\ \gamma_{xy}(2\varepsilon_{xy}) \\ \gamma_{yz}(2\varepsilon_{yz}) \\ \gamma_{zx}(2\varepsilon_{zx}) \end{array} \right\} = \frac{1}{E} \begin{bmatrix} 1 & -\nu & -\nu & 0 & 0 & 0 \\ -\nu & 1 & -\nu & 0 & 0 & 0 \\ -\nu & -\nu & 1 & 0 & 0 & 0 \\ 0 & 0 & 0 & 1+\nu & 0 & 0 \\ 0 & 0 & 0 & 0 & 1+\nu & 0 \\ 0 & 0 & 0 & 0 & 0 & 1+\nu \end{bmatrix} \left\{ \begin{array}{l} \sigma_{xx} \\ \sigma_{yy} \\ \sigma_{zz} \\ \tau_{xy} \\ \tau_{yz} \\ \tau_{zx} \end{array} \right\} \quad (2.53)$$

66 If we invert this equation, we obtain

$$\left\{ \begin{array}{l} \sigma_{xx} \\ \sigma_{yy} \\ \sigma_{zz} \\ \tau_{xy} \\ \tau_{yz} \\ \tau_{zx} \end{array} \right\} = \frac{E}{(1+\nu)(1-2\nu)} \begin{bmatrix} 1-\nu & \nu & \nu \\ \nu & 1-\nu & \nu \\ \nu & \nu & 1-\nu \end{bmatrix} \begin{bmatrix} \varepsilon_{xx} \\ \varepsilon_{yy} \\ \varepsilon_{zz} \\ \gamma_{xy}(2\varepsilon_{xy}) \\ \gamma_{yz}(2\varepsilon_{yz}) \\ \gamma_{zx}(2\varepsilon_{zx}) \end{bmatrix} + G \begin{bmatrix} 1 & 0 & 0 \\ 0 & 1 & 0 \\ 0 & 0 & 1 \end{bmatrix} \left\{ \begin{array}{l} \tau_{xy} \\ \tau_{yz} \\ \tau_{zx} \end{array} \right\} \quad (2.54)$$

2.2.4.2 Transversely Isotropic Case

67 For transversely isotropic, we can express the stress-strain relation in terms of

$$\begin{aligned} \varepsilon_{xx} &= a_{11}\sigma_{xx} + a_{12}\sigma_{yy} + a_{13}\sigma_{zz} \\ \varepsilon_{yy} &= a_{12}\sigma_{xx} + a_{11}\sigma_{yy} + a_{13}\sigma_{zz} \\ \varepsilon_{zz} &= a_{13}(\sigma_{xx} + \sigma_{yy}) + a_{33}\sigma_{zz} \\ \gamma_{xy} &= 2(a_{11} - a_{12})\tau_{xy} \\ \gamma_{yz} &= a_{44}\tau_{yz} \\ \gamma_{xz} &= a_{44}\tau_{xz} \end{aligned} \quad (2.55)$$

2.2.4.4 Pore Pressures

⁷³ In porous material, the water pressure is transmitted to the structure as a *body force* of magnitude

$$\boxed{b_x = -\frac{\partial p}{\partial x} \quad b_y = -\frac{\partial p}{\partial y}} \quad (2.61)$$

where p is the pore pressure.

⁷⁴ The *effective stresses* are the forces transmitted between the solid particles and are defined in terms of the *total stresses* σ and pore pressure p

$$\boxed{\sigma'_{ij} = \sigma_{ij} + m_{ij}p \quad \mathbf{m}^T = [-1, \quad -1, \quad 0]} \quad (2.62)$$

i.e simply removing the hydrostatic pressure component from the total stress.

2.2.5 † Field Equations for Thermo- and Poro Elasticity

Adapted from (Reich 1993)

⁷⁵ In the absence of thermal/initial stresses and pore pressures, the field equations are written as

$$\begin{aligned} \sigma'_{ij,j} + b_i &= 0 && \text{Equilibrium} \\ \sigma'_{ij} n_j - \hat{t}_i &= 0 && \text{Natural B.C.} \end{aligned} \quad (2.63)$$

where b_i and \hat{t}_i are the body forces and surface tractions respectively.

⁷⁶ These equations will form the basis of the variational formulation of the finite element method.

⁷⁷ To account for the effect of thermal/initial stresses and pore pressures we seek to modify Eq. 2.63, in such a way that b_i and \hat{t}_i are replaced by b'_i and \hat{t}'_i .

⁷⁸ Thermal strains are caused by a change in temperature with respect to the stress-free condition.

⁷⁹ In Thermo- or poro-elasticity problems, the thermal strains and pore pressures are treated as initial strains and stresses, respectively.

⁸⁰ In porous media, the total stress σ is equal to the sum of σ' and p . This last term is the pore pressures and acts only in the voids of the material, and the **effective stresses** σ' act only on the skeleton of the material, (Terzaghi and Peck 1967).

⁸¹ It must be noted that the pore pressures p being considered in this discussion and throughout the remainder of this course are the steady state pore pressures; excess pore pressures resulting from dilatant behavior in the skeleton of the material are not considered.

⁸² Step by step generalization of the field equations:

Initial thermal strain is caused by a change in temperature

$$\varepsilon_{ij}^0 = \alpha \Delta T \delta_{ij} \quad (2.64)$$

where ΔT is the temperature (change), α the coefficient of thermal expansion, δ_{ij} is the Kronecker delta,

Thermal stress is simply given by $\sigma''_{ij} = D_{ijkl} \varepsilon_{kl}^0$ or

$$\sigma''_{ij} = \alpha \Delta T D_{ijkl} \delta_{kl} \quad (2.65)$$

2.3 Scalar Field: Diffusion Equation

87 Scalar field problems are encountered in almost all branches of engineering and physics. Most of them can be viewed as special forms of the general Helmholtz equation given by

$$\frac{\partial}{\partial x} \left(k_x \frac{\partial \phi}{\partial x} \right) + \frac{\partial}{\partial y} \left(k_y \frac{\partial \phi}{\partial y} \right) + \frac{\partial}{\partial z} \left(k_z \frac{\partial \phi}{\partial z} \right) + Q = c\rho \frac{\partial \phi}{\partial t} \quad (2.77)$$

where $\phi(x, y, z)$ is the field variable to be solved.

88 Table 2.1 illustrates selected examples of the diffusion equation.

div($\mathbf{D}\nabla\phi$) + $Q = 0$					
Equation	ϕ	\mathbf{D}	Q	\mathbf{q}	Constitutive law
Heat Flow	Temperature T	Thermal conductivity	Heat supply/sink	Heat flux	Fourier $\mathbf{q} = -\mathbf{D}\nabla T$
Fluid flow through porous media	Piezometric head h	Permeability Coefficients	Fluid supply	Volume flux	Darcy $\mathbf{q} = -\mathbf{D}\nabla\phi$
Diffusion	ion concentration	Permeability coefficients	Ion supply	Ion flux	Fick $\mathbf{q} = -\mathbf{D}\nabla\phi$
Saint-Venant Torsion	Prandtl's stress function	$\frac{1}{\mu}$	Rate of twist $\frac{\theta}{2}$		Hooke

Table 2.1: Selected Examples of Diffusion Problems

2.3.1 Heat Transfer

89 There are three fundamental modes of heat transfer:

Conduction: takes place when a temperature gradient exists within a material and is governed by Fourier's Law, Fig. 2.5 on Γ_q :

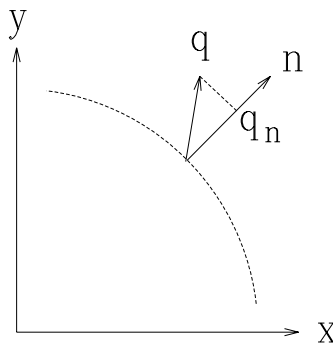

Figure 2.5: Flux vector

$$q_x = -k_x \frac{\partial T}{\partial x} \quad (2.78)$$

$$q_y = -k_y \frac{\partial T}{\partial y} \quad (2.79)$$

where $T = T(x, y)$ is the temperature field in the medium, q_x and q_y are the components of the heat flux (W/m^2 or $\text{Btu}/\text{h}\cdot\text{ft}^2$), k is the thermal conductivity ($\text{W}/\text{m}\cdot^\circ\text{C}$ or $\text{Btu}/\text{h}\cdot\text{ft}\cdot^\circ\text{F}$) and $\frac{\partial T}{\partial x}$,

Draft

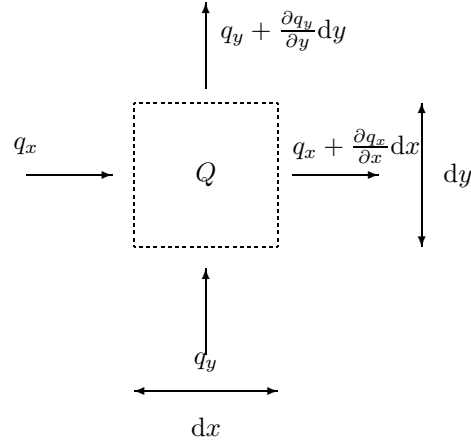

Figure 2.6: Flux Through Sides of Differential Element

Figure 2.7: *Flow through a surface Γ

- 2. Heat flux across the boundary of the element is shown in Fig. ?? (note similarity with equilibrium equation)

$$I_1 = \left[\left(q_x + \frac{\partial q_x}{\partial x} dx \right) - q_x dx \right] dy + \left[\left(q_y + \frac{\partial q_y}{\partial y} dy \right) - q_y dy \right] dx = \frac{\partial q_x}{\partial x} dx dy + \frac{\partial q_y}{\partial y} dy dx \quad (2.86)$$

- 3. Change in stored energy is

$$I_3 = c\rho \frac{d\phi}{dt} . dx dy \quad (2.87)$$

where we define the *specific heat* c as the amount of heat required to raise a unit mass by one degree.

⁹³ From the first law of thermodynamics, energy produced I_2 plus the net energy across the boundary I_1 must be equal to the energy absorbed I_3 , thus

$$I_1 + I_2 - I_3 = 0 \quad (2.88-a)$$

$$\underbrace{\frac{\partial q_x}{\partial x} dx dy + \frac{\partial q_y}{\partial y} dy dx}_{I_1} + \underbrace{Q dx dy}_{I_2} - \underbrace{c\rho \frac{d\phi}{dt} dx dy}_{I_3} = 0 \quad (2.88-b)$$

2.3.2.2 †Generalized Derivation

⁹⁴ The amount of flow per unit time into an element of volume Ω and surface Γ is

$$I_1 = \int_{\Gamma} \mathbf{q}(-\mathbf{n})d\Gamma = \int_{\Gamma} \mathbf{D}\nabla\phi.\mathbf{n}d\Gamma \quad (2.89)$$

where \mathbf{n} is the unit exterior normal to Γ , Fig. 2.7

⁹⁵ Using the divergence theorem

$$\int_{\Gamma} \mathbf{v}.\mathbf{n}d\Gamma = \int_{\Omega} \text{div } \mathbf{v}d\Omega \quad (2.90)$$

Draft

4. If the heat input $Q = 0$, then the previous equation reduces to

$$\frac{\partial^2 \phi}{\partial x^2} + \frac{\partial^2 \phi}{\partial y^2} + \frac{\partial^2 \phi}{\partial z^2} = 0 \tag{2.101}$$

which is an **Elliptic** (or *Laplace*) equation. Solutions of Laplace equations are termed *harmonic functions* (right hand side is zero) which is why Eq. 2.99 is referred to as the *quasi-harmonic* equation.

5. If the function depends only on x and t , then we obtain

$$\rho c \frac{\partial \phi}{\partial t} = \frac{\partial}{\partial x} \left(k_x \frac{\partial \phi}{\partial x} \right) + Q \tag{2.102}$$

which is a **parabolic** (or Heat) equation.

2.3.2.3 Boundary Conditions

The boundary conditions, for thermal problems, are mainly of three kinds:

Essential: Temperature prespecified on Γ_T

Natural: Flux

Specified Flux prescribed on Γ_q , $q_n = \text{cst}$

Convection Flux prescribed on Γ_c , $q_c = h(T - T_\infty)$. Note this type of boundary condition is analogous to the one in structural mechanics where we have an inclined support on rollers.

similar boundary conditions can be written for fluid flow.

2.4 Summary and Tonti Diagrams

⁹⁹ The analogy between scalar and vector problems is shown in Table 2.2.

Scalar	Vector	
Conduction	Solid Mechanics	
Variables		
T	\mathbf{u}	State
g	$\boldsymbol{\varepsilon}$	Intermediate
\mathbf{q}	$\boldsymbol{\sigma}$	Flux
Field Equations		
$\text{div } \mathbf{q} + Q = 0$	$\mathbf{L}^T \boldsymbol{\sigma} + \mathbf{b} = 0$	Balance
$g = \nabla T$	$\boldsymbol{\varepsilon} = \mathbf{L} \mathbf{u}$	kinematic
$\underbrace{\mathbf{q} = -\mathbf{D}g}_{\text{Fourrier}}$	$\underbrace{\boldsymbol{\sigma} = \mathbf{D}\boldsymbol{\varepsilon}}_{\text{Hooke}}$	Constitutive
Boundary Conditions		
T on Γ_T	\mathbf{u} on Γ_u	Essential BC
$q_n = \mathbf{q}^T \mathbf{n}$ on $\Gamma_q \cup \Gamma_c$	$\mathbf{t} = \boldsymbol{\sigma} \mathbf{n}$ on Γ_t	Natural BC (Flux)

Table 2.2: Comparison of Scalar and Vector Field Problems

¹⁰⁰ To graphically illustrate the inter-relationship between field equations and variables, Tonti diagrams, Fig. 2.8 have been used.

Draft

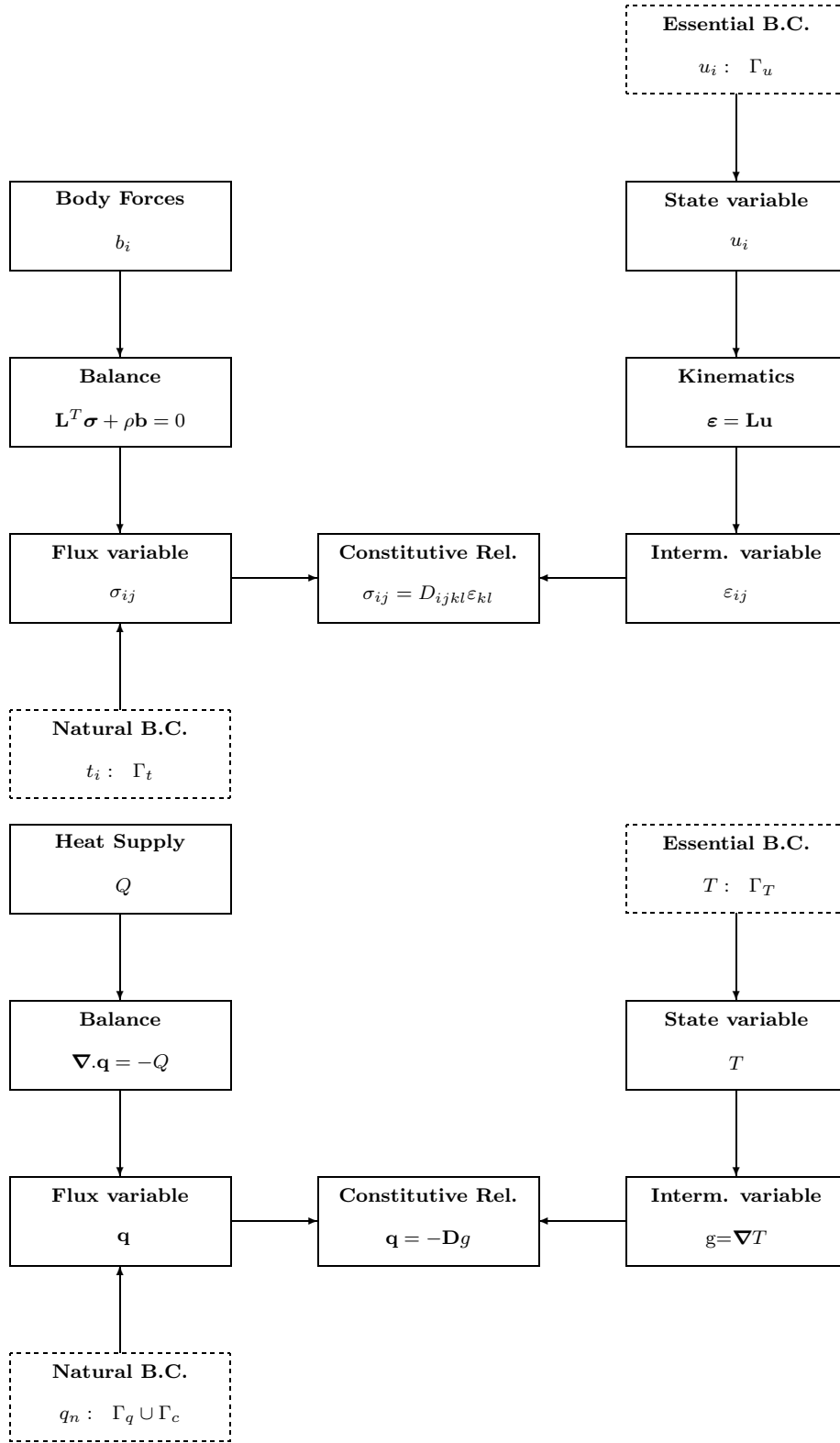

Figure 2.9: Fundamental Equations of Solid Mechanics and Heat Flow

Chapter 3

MESH GENERATION

Requires further editing

3.1 Introduction

¹ Finite element mesh generation is now an integral part of a finite element analysis. With the increased computational capabilities, increasingly more complex structures are being analysed. Those structures must be discretized.

² The task is one of developing a mathematical model (discretization or tessalation) of a continuum model. This is not only necessary in finite element analysis, but in computer graphics/rendering also.

³ In computer graphics, we focus on the boundary representation, and assign colors and shades on the basis of light source and outward normal direction of the polygon.

⁴ Hence, in the most general case, meshing can be defined as the process of breaking up a physical domain into smaller sub-domains (elements) in order to facilitate the numerical solution of a partial differential equation. Surface domains may be subdivided into triangle or quadrilateral shapes, while volumes may be subdivided primarily into tetrahedra or hexahedra shapes. The shape and distribution of the elements is ideally defined by automatic meshing algorithms.

1. Point placement, followed by triangularization (discussed below).
2. Sub-domain removal. Elements are gradually removed from the domain, one at a time, until the whole domain is decomposed into finite elements.
3. Recursive subdivision. The domain is broken into simpler parts until the individual parts are single elements or simple regions, that can be meshed directly, for instance by the conformal mapping algorithm.
4. Hierarchical decomposition. The basic principle of a quadtree (or hierarchical decomposition) is to cover a planar region of interest by a square, then recursively partition squares into smaller squares until each square contains a suitably uniform subset of the input.

3.2 Triangulation

⁵ The concept of Voronoi diagrams first appeared in works of Descartes as early as 1644. Descartes used Voronoi-like diagrams to show the disposition of matter in the solar system and its environs.

⁶ The first man who studied the Voronoi diagram as a concept was a German mathematician G. L. Dirichlet. He studied the two- and three dimensional case and that is why this concept is also known as

Chapter 4

VARIATIONAL and RAYLEIGH-RITZ METHODS

Adapted from (Reich 1993)

4.1 Multifield Variational Principles

¹ A **Multifield** variational principle is one that has more than one master field (or state variable), that is more than one unknown field is subject to independent variations.

² In linear elastostatics, we can have displacement, \mathbf{u} , strains $\boldsymbol{\varepsilon}$, or stress $\boldsymbol{\sigma}$ as potential candidates for master fields. Hence seven combinations are possible, (Felippa 2000), Table 4.1.

³ In this course, we shall focus on only the Total Potential Energy, and the Hu-Washizu variational principles.

\mathbf{u}	$\boldsymbol{\varepsilon}$	$\boldsymbol{\sigma}$	Name
Single Field			
Y		Y	Total Potential Energy
	Y		Total Complementary Potential Energy
			No name
Two Fields			
Y		Y	Hellinger-Reissner
Y	Y		de Veubeke
	Y	Y	No name
Three Fields			
Y	Y	Y	Hu-Washizu

Table 4.1: Functionals in Linear Elasticity

2. **In terms of displacements:** (using Equation 4.7) which is more suitable for the subsequent discretization.

$$\delta\Pi = \underbrace{\int_{\Omega} \delta(\mathbf{L}\mathbf{u})^T \mathbf{D}(\mathbf{L}\mathbf{u}) d\Omega - \int_{\Omega} \delta(\mathbf{L}\mathbf{u})^T \mathbf{D}\boldsymbol{\epsilon}_0 d\Omega + \int_{\Omega} \delta(\mathbf{L}\mathbf{u})^T \boldsymbol{\sigma}_0 d\Omega}_{\delta U} - \underbrace{\int_{\Omega} \delta\mathbf{u}^T \mathbf{b} d\Omega - \int_{\Gamma_t} \delta\mathbf{u}^T \hat{\mathbf{t}} d\Gamma}_{-\delta W_e} = 0$$

10 To obtain the Euler equations for the general form of the potential energy variational principle the volume integrals defining the virtual strain energy δU in Equation 4.7 must be integrated by parts in order to convert the variation of the strains $\delta(\mathbf{L}\mathbf{u})$ into a variation of the displacements $\delta\mathbf{u}$.

11 Integration by parts of these integrals using Green's theorem (Eq. 1.40)

$$\int_{\Omega} R \frac{\partial S}{\partial x} d\Omega = - \int_{\Omega} \frac{\partial R}{\partial x} S d\Omega + \oint_{\Gamma} R S n_x d\Gamma \quad (4.7)$$

yields

$$\int_{\Omega} \delta(\mathbf{L}\mathbf{u})^T \mathbf{D}\boldsymbol{\epsilon} d\Omega = \oint_{\Gamma} \delta\mathbf{u}^T \mathbf{G}(\mathbf{D}\boldsymbol{\epsilon}) d\Gamma - \int_{\Omega} \delta\mathbf{u}^T \mathbf{L}^T (\mathbf{D}\boldsymbol{\epsilon}) d\Omega \quad (4.8-a)$$

$$\int_{\Omega} \delta(\mathbf{L}\mathbf{u})^T \mathbf{D}\boldsymbol{\epsilon}_0 d\Omega = \oint_{\Gamma} \delta\mathbf{u}^T \mathbf{G}(\mathbf{D}\boldsymbol{\epsilon}_0) d\Gamma - \int_{\Omega} \delta\mathbf{u}^T \mathbf{L}^T (\mathbf{D}\boldsymbol{\epsilon}_0) d\Omega \quad (4.8-b)$$

$$\int_{\Omega} \delta(\mathbf{L}\mathbf{u})^T \boldsymbol{\sigma}_0 d\Omega = \oint_{\Gamma} \delta\mathbf{u}^T \mathbf{G}\boldsymbol{\sigma}_0 d\Gamma - \int_{\Omega} \delta\mathbf{u}^T \mathbf{L}^T \boldsymbol{\sigma}_0 d\Omega \quad (4.8-c)$$

where \mathbf{G} is a transformation matrix containing the direction cosines for a unit normal vector such that the surface tractions \mathbf{t} are defined as $\mathbf{t} = \mathbf{G}\boldsymbol{\sigma}$ and the surface integrals are over the entire surface of the body Γ .

12 Substituting Equation 4.8-a into Equation 4.7, the variational statement becomes

$$\delta\Pi = - \int_{\Omega} \delta\mathbf{u}^T \{ \mathbf{L}^T \underbrace{[\mathbf{D}(\boldsymbol{\epsilon} - \boldsymbol{\epsilon}_0) + \boldsymbol{\sigma}_0]}_{\boldsymbol{\sigma}} + \mathbf{b} \} d\Omega + \int_{\Gamma} \delta\mathbf{u}^T \{ \mathbf{G} \underbrace{[\mathbf{D}(\boldsymbol{\epsilon} - \boldsymbol{\epsilon}_0) + \boldsymbol{\sigma}_0]}_{\boldsymbol{\sigma}} - \hat{\mathbf{t}} \} d\Gamma = 0 \quad (4.9)$$

13 Since $\delta\mathbf{u}$ is arbitrary the expressions in the integrands within the braces must both be equal to zero for $\delta\Pi$ to be equal to zero. Recognizing that the stress-strain relationship appears in both the volume and surface integrals, the Euler equations are

$$\begin{array}{ll} \text{(BE): Equilibrium} & \mathbf{L}^T \boldsymbol{\sigma} + \mathbf{b} = \mathbf{0} \quad \text{on } \Omega \\ \text{(NBC): Natural B.C.} & \mathbf{G}\boldsymbol{\sigma} - \hat{\mathbf{t}} = \mathbf{0} \quad \text{on } \Gamma_t \end{array} \quad (4.10)$$

where the first Euler equation is the equilibrium equation and the second Euler equation defines the natural boundary conditions. The natural boundary conditions are defined on Γ_t rather than Γ because both the applied surface tractions $\hat{\mathbf{t}}$ and the matrix-vector product $\mathbf{G}\boldsymbol{\sigma}$ are identically zero outside Γ_t .

14 In general, only certain forms of differential equations are Euler equations of a variational functional.

15 For the elastostatic problem, it is possible to start from the Euler equations, and then derive the total potential energy functional by performing the operations just presented in reverse order.

16 The Tonti diagram for the TPE is shown in Fig. 4.2. In this diagram, strong connections are shown by solid lines, weak connections by spring-like symbols, boxes with solid lines denote the primary unknown field, variables inside dashed boxes are internally derived fields, and shaded boxes indicate prescribed fields.

The Kinetic energy is given by

$$K = \int_{\Omega} \frac{\rho}{2} \frac{\partial \mathbf{u}}{\partial t} \cdot \frac{\partial \mathbf{u}}{\partial t} d\Omega \quad (4.17)$$

A conservative force is one for which the sum of the potential and kinetic energies is conserved).

■ Example 4-1: Hamilton's Principle

For a uniform cross section bar of length L , cross sectional area A , Young's modulus E , and mass density ρ fixed at one end, and connected to a rigid support at the other by a spring with stiffness k

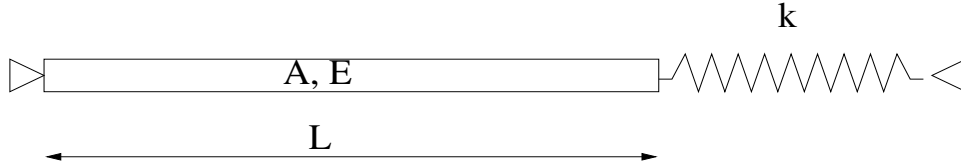

1. Show that the kinetic energy and the strain energy are given by

$$K = \int_0^L \frac{\rho A}{2} \left(\frac{\partial u}{\partial t} \right)^2 dx \quad (4.18)$$

$$U = \int_0^L \frac{EA}{2} \left(\frac{\partial u}{\partial x} \right)^2 d\Omega + \frac{k}{2} [u(L)]^2 \quad (4.19)$$

2. For $W_{nc} = 0$ derive an expression for the first variation of the Hamilton's functional $\delta \Pi_H$

3. If we are interested in determining the periodic motion, which has the form

$$u(x, t) = u_0(x) e^{i\omega t} \quad (4.20)$$

where ω is the frequency of natural vibration, and $u_0(x)$ is the amplitude. Show that

$$\delta \left\{ \int_0^L \frac{1}{2} \left[\rho A \omega^2 (u_0)^2 - EA \left(\frac{du_0}{dx} \right)^2 \right] dx - \frac{k}{2} [u_0(L)]^2 \right\} = 0 \quad (4.21)$$

4. Show that the Euler equations of the preceding functional are

$$\frac{d}{dx} \left(EA \frac{du_0}{dx} \right) + \rho A \omega^2 u_0 = 0 \quad \text{for } 0 < x < L \quad (4.22)$$

$$\left(EA \frac{du_0}{dx} + k u_0 \right) = 0 \quad \text{for } x = L \quad (4.23)$$

5. Rewrite Eq. 4.21 in terms of $\bar{x} = \frac{x}{L}$, $\bar{u} = \frac{u_0}{L}$, $\alpha = \frac{kL}{EA}$, $\lambda = \frac{\omega^2 \rho L^2}{E}$

6. Show that if this problem was to be solved by the Rayleigh-Ritz method with

$$u = c_1 x + c_2 x^2 \quad (4.24)$$

then a nontrivial solution $c_1 \neq 0$ and $c_2 \neq 0$ exists if and only if

$$15\lambda^2 - 640\lambda + 2400 = 0 \quad (4.25)$$

7. Solve for ω_1 and ω_2 , and compare with the exact solution given by

$$\lambda + \tan \lambda = 0 \quad (4.26)$$

Chapter 5

INTERPOLATION FUNCTIONS; NATURAL COORDINATE SYSTEMS

5.1 Introduction

¹ In the Rayleigh Ritz method we solved the variational problem using a functional approximation for the displacement field (Chapter ??). This powerful method has its limitation in terms of the complexity of solvable problems.

² As stated above, an alternate approach consists in adopting an approximate displacement field in terms of the *nodal displacements* via interpolation functions (or shape functions).

5.2 Cartesian Coordinate System

³ For an element (finite or otherwise), we can write an expression for the generalized displacement (translation/rotation), u at any point in terms of all its nodal ones, $\bar{\mathbf{u}}$.

$$u = \sum_{i=1}^n N_i(X) \bar{\Delta}_i = [\mathbf{N}(x)] \{\bar{\mathbf{u}}\} \quad (5.1)$$

where:

1. \bar{u}_i is the (generalized) nodal displacement corresponding to d.o.f i
2. N_i is an interpolation function, or **shape function** which has the following characteristics:
 - (a) $N_i = 1$ at \bar{u}_i
 - (b) $N_i = 0$ at \bar{u}_j where $i \neq j$.
3. \mathbf{N} can be derived on the bases of:
 - (a) Assumed deformation state defined in terms of polynomial series.
 - (b) Interpolation function (Lagrangian or Hermitian).

⁴ We shall distinguish between two classes of problems:

Draft

5.2.1.2 Generalization

9 The previous derivation can be generalized by writing:

$$u = a_1x + a_2 = \underbrace{\begin{bmatrix} x & 1 \end{bmatrix}}_{[\mathbf{p}]} \underbrace{\begin{Bmatrix} a_1 \\ a_2 \end{Bmatrix}}_{\{\mathbf{a}\}} \quad (5.12)$$

where $[\mathbf{p}]$ corresponds to the polynomial approximation, and $\{\mathbf{a}\}$ is the coefficient vector.

10 We next apply the boundary conditions:

$$\underbrace{\begin{Bmatrix} \bar{u}_1 \\ \bar{u}_2 \end{Bmatrix}}_{\{\bar{\mathbf{u}}\}} = \underbrace{\begin{bmatrix} 0 & 1 \\ L & 1 \end{bmatrix}}_{[\mathcal{L}]} \underbrace{\begin{Bmatrix} a_1 \\ a_2 \end{Bmatrix}}_{\{\mathbf{a}\}} \quad (5.13)$$

following inversion of $[\mathcal{L}]$, this leads to

$$\underbrace{\begin{Bmatrix} a_1 \\ a_2 \end{Bmatrix}}_{\{\mathbf{a}\}} = \underbrace{\frac{1}{L} \begin{bmatrix} -1 & 1 \\ L & 0 \end{bmatrix}}_{[\mathcal{L}]^{-1}} \underbrace{\begin{Bmatrix} \bar{u}_1 \\ \bar{u}_2 \end{Bmatrix}}_{\{\bar{\mathbf{u}}\}} \quad (5.14)$$

11 Substituting this last equation into Eq. 5.12, we obtain:

$$u = \underbrace{\begin{bmatrix} (1 - \frac{x}{L}) & \frac{x}{L} \end{bmatrix}}_{\underbrace{[\mathbf{p}][\mathcal{L}]^{-1}}_{[\mathbf{N}]}} \underbrace{\begin{Bmatrix} \bar{u}_1 \\ \bar{u}_2 \end{Bmatrix}}_{\{\bar{\mathbf{u}}\}} \quad (5.15)$$

12 Hence, the shape functions $[\mathbf{N}]$ can be directly obtained from

$$\boxed{[\mathbf{N}] = [\mathbf{p}][\mathcal{L}]^{-1}} \quad (5.16)$$

13 Note that in some cases \mathcal{L}^{-1} is not always possible to obtain, and that in others there may be considerable algebraic difficulties for arbitrary geometries. Hence, we shall introduce later on Lagrangian and Hermitian interpolation functions.

5.2.1.3 Constant Strain Triangle Element

14 Next we consider a triangular element, Fig. 5.2 with *bi-linear* displacement field (in both x and y):

$$u = a_1 + a_2x + a_3y \quad (5.17)$$

$$v = a_4 + a_5x + a_6y \quad (5.18)$$

$$u = \underbrace{\begin{bmatrix} 1 & x & y \end{bmatrix}}_{[\mathbf{p}]} \underbrace{\begin{Bmatrix} a_1 \\ a_2 \\ a_3 \end{Bmatrix}}_{\{\mathbf{a}\}} \quad (5.19)$$

Chapter 6

FINITE ELEMENT DISCRETIZATION and REQUIREMENTS

6.1 Discretization

This section is mostly extracted from (Reich 1993)

6.1.1 Discretization of the Variational Statement for the General TPE Variational Principle

¹ The discretization of Equation 4.7 will be performed on an element domain Ω_e using the procedures described in Chapter 2 of (Zienkiewicz and Taylor 1989);

² The surface of the element subjected to surface tractions Γ_t comprises one or more surfaces of the element boundary Γ . For the present time this discussion will be kept on a very general level with no mention of the dimensionality of the elements; the number of nodes defining the elements; or the nature of the constitutive law.

³ The first step in the discretization process is to define the displacements \mathbf{u} at a point inside the element in terms of the shape functions \mathbf{N} and the nodal displacements $\bar{\mathbf{u}}_e$ for the element

$$\mathbf{u} = \mathbf{N}\bar{\mathbf{u}}_e \quad (6.1)$$

⁴ The virtual displacements $\delta\mathbf{u}$ at a point inside the element can also be defined in terms of the shape functions \mathbf{N} and the nodal virtual displacements $\delta\bar{\mathbf{u}}_e$ for the element

$$\delta\mathbf{u} = \mathbf{N}\delta\bar{\mathbf{u}}_e \quad (6.2)$$

⁵ In order to discretize the volume integral in Equation 4.7

$$\delta\Pi = \int_{\Omega} \delta(\mathbf{L}\mathbf{u})^T \mathbf{D}(\mathbf{L}\mathbf{u}) d\Omega - \int_{\Omega} \delta(\mathbf{L}\mathbf{u})^T \mathbf{D}\boldsymbol{\epsilon}_0 d\Omega + \int_{\Omega} \delta(\mathbf{L}\mathbf{u})^T \boldsymbol{\sigma}_0 d\Omega - \int_{\Omega} \delta\mathbf{u}^T \mathbf{b} d\Omega - \int_{\Gamma_t} \delta\mathbf{u}^T \hat{\mathbf{t}} d\Gamma = 0 \quad (6.3)$$

Draft

$$\int_{\Gamma_t} \delta \mathbf{u}^T \hat{\mathbf{t}} d\Gamma = \delta \bar{\mathbf{u}}_e^T \int_{\Gamma_t} \mathbf{N}^T \hat{\mathbf{t}} d\Gamma \quad (6.15)$$

11 Defining the applied force vector \mathbf{f}_e as

$$\mathbf{f}_e = \int_{\Omega_e} \mathbf{N}^T \mathbf{b} d\Omega + \int_{\Gamma_t} \mathbf{N}^T \hat{\mathbf{t}} d\Gamma \quad (6.16)$$

the sum of the internal and external virtual work due to body forces and surface tractions is

$$\int_{\Omega_e} \delta \mathbf{u}^T \mathbf{b} d\Omega + \int_{\Gamma_t} \delta \mathbf{u}^T \hat{\mathbf{t}} d\Gamma = \delta \bar{\mathbf{u}}_e^T \mathbf{f}_e \quad (6.17)$$

12 Having obtained the discretization of the various integrals defining the variational statement for the TPE variational principle, it is now possible to define the discrete system of equations. Substituting Equations 6.7, 6.13, and 6.17 into Equation 6.3 and rearranging terms, the discretized Principle of Virtual Work is

$$\delta \bar{\mathbf{u}}_e^T \mathbf{K}_e \bar{\mathbf{u}}_e = \delta \bar{\mathbf{u}}_e^T \mathbf{f}_e + \delta \bar{\mathbf{u}}_e^T \mathbf{f}_{0_e} \quad (6.18)$$

13 Since $\delta \bar{\mathbf{u}}_e^T$ is an arbitrary (i.e. non-zero) vector appearing on both sides of Equation 6.18, the discrete system of equations can be simplified into

$$\mathbf{K}_e \bar{\mathbf{u}}_e = \mathbf{f}_e + \mathbf{f}_{0_e} + \mathbf{P} \mathbf{u} \quad (6.19)$$

as the discrete system of equations for an element.

6.1.2 Discretization of the Variational Statement for the HW Variational Principle

14 The discretization of the three variational statements defined in Equation 4.62, 4.62, and 4.62 will be performed on an element domain Ω_e using the procedures described in Chapter 2 of (Zienkiewicz and Taylor 1989) assembly of the discrete element equations into a discrete global system of equations is straightforward and will be omitted from this discussion.

15 The surface of the element subjected to surface tractions Γ_t comprises one or more surfaces of the element boundary Γ_e . For the present time this discussion will be kept on a very general level with no mention of the dimensionality of the elements; the number of nodes defining the elements; or the nature of constitutive law.

16 The first step in the discretization process is to define the displacements \mathbf{u} , strains $\boldsymbol{\epsilon}$, and stresses $\boldsymbol{\sigma}$ at a point inside the element in terms of the shape functions \mathbf{N}_u , \mathbf{N}_ϵ , and \mathbf{N}_σ , respectively, and the element nodal displacements $\bar{\mathbf{u}}_e$, strains $\bar{\boldsymbol{\epsilon}}_e$, and stresses $\bar{\boldsymbol{\sigma}}_e$

$$\begin{aligned} \mathbf{u} &= \mathbf{N}_u \bar{\mathbf{u}}_e \\ \boldsymbol{\epsilon} &= \mathbf{N}_\epsilon \bar{\boldsymbol{\epsilon}}_e \\ \boldsymbol{\sigma} &= \mathbf{N}_\sigma \bar{\boldsymbol{\sigma}}_e \end{aligned} \quad (6.20)$$

We note that contrarily to the previous case (Eq. 6.1) we now have three discretizations (instead of just one).

17 The virtual displacements $\delta \mathbf{u}$, virtual strains $\delta \boldsymbol{\epsilon}$, and virtual stresses $\delta \boldsymbol{\sigma}$ at a point inside the element can also be defined in terms of the shape functions \mathbf{N}_u , \mathbf{N}_ϵ , and \mathbf{N}_σ , respectively, and the nodal virtual

Draft

the sum of the internal and external virtual work is

$$\int_{\Omega_e} \delta \mathbf{u}^T \mathbf{b} \, d\Omega + \int_{\Gamma_t} \delta \mathbf{u}^T \hat{\mathbf{t}} \, d\Gamma = \delta \bar{\mathbf{u}}_e^T \mathbf{f}_e \quad (6.31)$$

²³ Having defined the discretization of the various integrals in the first variational statement for the HW variational principle (i.e. Equ. 6.22-a), it is now possible to define the discrete system of equations. Substituting Equations 6.27 and 6.31 into the variational statement and rearranging terms, the discretized Principle of Virtual Work is

$$\delta \bar{\mathbf{u}}_e^T \mathbf{F}_e^T \bar{\boldsymbol{\sigma}}_e = \delta \bar{\mathbf{u}}_e^T \mathbf{f}_e \quad (6.32)$$

where the left-hand side is the virtual strain energy and the right-hand side is the internal and external virtual work. Since $\delta \bar{\mathbf{u}}_e$ is an arbitrary (i.e. non-zero) vector appearing on both sides of Equation 6.32, the discrete system of equations can be simplified into

$$\boxed{\mathbf{F}_e^T \bar{\boldsymbol{\sigma}}_e = \mathbf{f}_e} \quad (6.33)$$

as the discrete system of equations for an element.

²⁴ In order to discretize the second variational statement (i.e. Equ. 6.22-b), Equations 6.20, 6.20, and 6.21-b are substituted into the integrand

$$\begin{aligned} \int_{\Omega} \delta \boldsymbol{\epsilon}^T [\mathbf{D}(\boldsymbol{\epsilon} - \boldsymbol{\epsilon}_0) + \boldsymbol{\sigma}_0 - \boldsymbol{\sigma}] \, d\Omega &= \delta \bar{\boldsymbol{\epsilon}}_e^T \int_{\Omega_e} \mathbf{N}_\epsilon^T \mathbf{D} \mathbf{N}_\epsilon \, d\Omega \bar{\boldsymbol{\epsilon}}_e - \delta \bar{\boldsymbol{\epsilon}}_e^T \int_{\Omega_e} \mathbf{N}_\epsilon^T \mathbf{D} \boldsymbol{\epsilon}_0 \, d\Omega \\ &+ \delta \bar{\boldsymbol{\epsilon}}_e^T \int_{\Omega_e} \mathbf{N}_\epsilon^T \boldsymbol{\sigma}_0 \, d\Omega - \delta \bar{\boldsymbol{\epsilon}}_e^T \int_{\Omega_e} \mathbf{N}_\epsilon^T \mathbf{N}_\sigma \, d\Omega \bar{\boldsymbol{\sigma}}_e = 0 \end{aligned} \quad (6.34)$$

²⁵ Defining a pair of element operator matrices \mathbf{A}_e and \mathbf{C}_e as

$$\mathbf{A}_e = \int_{\Omega_e} \mathbf{N}_\epsilon^T \mathbf{D} \mathbf{N}_\epsilon \, d\Omega \quad (6.35)$$

$$\mathbf{C}_e = \int_{\Omega_e} \mathbf{N}_\epsilon^T \mathbf{N}_\sigma \, d\Omega \quad (6.36)$$

and the initial strain/stress vector \mathbf{g}_e as

$$\mathbf{g}_e = \int_{\Omega_e} \mathbf{N}_\epsilon^T \mathbf{D} \boldsymbol{\epsilon}_0 \, d\Omega - \int_{\Omega_e} \mathbf{N}_\epsilon^T \boldsymbol{\sigma}_0 \, d\Omega \quad (6.37)$$

Equation 6.34 can be rewritten as

$$\int_{\Omega} \delta \boldsymbol{\epsilon}^T [\mathbf{D}(\boldsymbol{\epsilon} - \boldsymbol{\epsilon}_0) + \boldsymbol{\sigma}_0 - \boldsymbol{\sigma}] \, d\Omega = \delta \bar{\boldsymbol{\epsilon}}_e^T \mathbf{A}_e \bar{\boldsymbol{\epsilon}}_e - \delta \bar{\boldsymbol{\epsilon}}_e^T \mathbf{g}_e - \delta \bar{\boldsymbol{\epsilon}}_e^T \mathbf{C}_e \bar{\boldsymbol{\sigma}}_e = 0 \quad (6.38)$$

Since the nodal virtual strains $\delta \bar{\boldsymbol{\epsilon}}$ are arbitrary they can be eliminated from Equation 6.38 yielding

$$\boxed{\mathbf{A}_e \bar{\boldsymbol{\epsilon}}_e - \mathbf{C}_e \bar{\boldsymbol{\sigma}}_e = \mathbf{g}_e} \quad (6.39)$$

as the discretized form of the second variational statement.

²⁶ In order to discretize the third variational statement (i.e. Eq. 6.22-c), Equations 6.20, 6.20, and 6.21-c are substituted into the integrand

$$\int_{\Omega_e} \delta \boldsymbol{\sigma}^T (\mathbf{L} \mathbf{u} - \boldsymbol{\epsilon}) \, d\Omega = \delta \bar{\boldsymbol{\sigma}}_e^T \int_{\Omega_e} \mathbf{N}_\sigma^T \mathbf{B}_u \, d\Omega \bar{\mathbf{u}}_e - \delta \bar{\boldsymbol{\sigma}}_e^T \int_{\Omega_e} \mathbf{N}_\sigma^T \mathbf{N}_\epsilon \, d\Omega \bar{\boldsymbol{\epsilon}}_e = 0 \quad (6.40)$$

6.2 General Element Requirements

³¹ A finite element (just a an approximate displacement field in the Rayleigh-Ritz formulation) must satisfy two basic **requirements**

Completeness: The FE discretization must *at least* accommodate constant displacement and constant strain (or temperature and temperature gradient). This is accomplished by including in two dimensional problems the following

$$\phi = a_1 + a_2x + a_3y + \text{possibly additional terms} \quad (6.48)$$

Compatibility or Conformity: The approximation of the field over element boundaries must be continuous (C^0 or C^1 continuity). Most finite elements are conforming, but some are not.

³² For instance, with respect to Fig. 6.1, element A must be capable of undergoing rigid body motion without internal strains/stresses, and at node B we should have continuity of displacement (but not slope for this element).

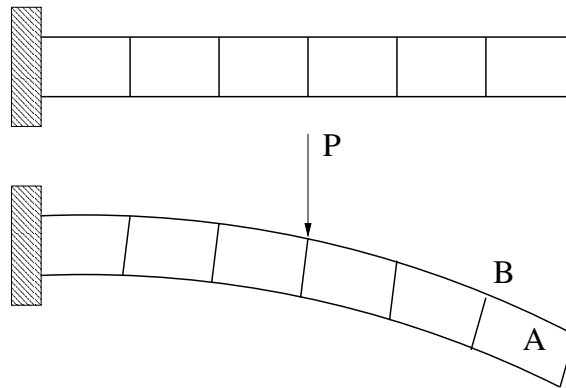

Figure 6.1: Completeness and Compatibility

³³ If those two requirements are satisfied, then **convergence** is assured. In the FE method approximate solution are obtained, and the more elements we use, the more accurate is the approximate solution. In the limit, for infinitely small elements, we require the solution to be also infinitely close to the exact one. Hence, convergence is ensured if completeness and compatibility requirements are satisfied.

³⁴ **Lax equivalence theorem:**

Convergence criterion=completeness+ compatibility requirements

³⁵ Two essential requirements:

Patch test: Completeness can be assessed through the **patch test** which will be discussed later.

Zero Strain Energy: For structural problems, there should be zero strain energy when the element is subjected to a rigid body motion. Recall that in the stiffness matrix formulation, the matrix is singular as it embodies not only the force displacement relations, but the equilibrium equations also. To each of those equations, corresponds a rigid body mode which can be detected by an eigenvalue analysis (more about this later).

Draft

A third form of acceleration is the so called **r** refinement in which the same number of nodes/elements is retained but the mesh is shifted around to increase its density in zones of high stress gradient.

43 The above convergence procedures can be accelerated within the context of a program which can accommodate **adaptive remeshing** techniques.

44 Finally, additional errors may come from **round-off** within the computer.

6.4 Lower Bound Character of Minimum Potential Energy Based Solutions

45 A numerical solution that is derived from the principle of minimum total potential energy is a **lower bound** solution, because the strain energy is smaller than the exact one (i.e. obtained from an infinite number of elements).

46 This can be readily shown if we consider the displacement u_i caused by a load P_i which is increased from zero to its stipulated value. The work done is $\frac{P_i u_i}{2}$ and must be equal to the internal strain energy U . Alternatively, the potential of the applied load is $P_i u_i$, and the exact potential energy is

$$\Pi_{exact} = \frac{P_i u_i^{exact}}{2} - P_i u_i^{exact} = -\frac{P_i u_i^{exact}}{2} \quad (6.51)$$

similarly, the approximate value of the potential energy is

$$\Pi_{approx} = -\frac{P_i u_i^{approx}}{2} \quad (6.52)$$

We know that the approximation of Π is **algebraically** higher than the exact value (since the exact value is a minimum), hence

$$\underbrace{-\frac{P_i u_i^{exact}}{2}}_{\Pi_{exact}} < \underbrace{-\frac{P_i u_i^{approx}}{2}}_{\Pi_{approx}} \quad (6.53)$$

or

$$\boxed{u_i^{approx} < u_i^{exact}} \quad (6.54)$$

or alternatively, the solution is **too stiff**.

47 Note the similarity with the Rayleigh-Ritz method, the lack of enough terms in our polynomial approximation did also result in a stiff solution.

6.5 Equilibrium and Compatibility in the Solution

48 In an **exact solution** over each differential element equilibrium and compatibility prevails.

49 In a **finite element** discretization, this is not necessarily the case:

Equilibrium of Nodal Forces: Those are automatically satisfied by definition ($\mathbf{k}^e \bar{\mathbf{u}} - \bar{\mathbf{f}} = 0$) at the nodes.

Compatibility at Nodes: Elements connected to one another have the same displacements (along corresponding dof) at the connecting node.

Interelement Continuity of Stress: is usually not satisfied, that is equilibrium across the elements does not necessarily prevail. For example consider Fig. 6.3 if node 4 is the only one displaced (all others remaining fixed), then there will be a discontinuity of σ_{xx} across element boundary 2-3.

Chapter 7

STRAIGHT SIDED ELEMENTS; 1st GENERATION

7.1 Introduction

¹ Having first introduced the method of virtual displacements, than the interpolation (or shape) functions $[\mathbf{N}]$, which relate internal to external nodal displacements, and finally having applied the virtual displacement method to finite element in chapter 6, we derive the stiffness matrices of some simple elements.

7.2 Rod Elements

7.2.1 Truss Element

² The shape functions of the truss element were derived in Eq. 5.11:

$$\begin{aligned} N_1 &= 1 - \frac{x}{L} \\ N_2 &= \frac{x}{L} \end{aligned}$$

³ The corresponding strain displacement relation $[\mathbf{B}]$ is given by:

$$\begin{aligned} \varepsilon_{xx} &= \frac{du}{dx} \\ &= \left[\frac{dN_1}{dx} \quad \frac{dN_2}{dx} \right] \\ &= \underbrace{\left[-\frac{1}{L} \quad \frac{1}{L} \right]}_{[\mathbf{B}]} \end{aligned} \tag{7.1}$$

⁴ For the truss element, the constitutive matrix $[\mathbf{D}]$ reduces to the scalar E ; Hence, substituting into Eq. 0.15 $[\mathbf{k}^e] = \int_{\Omega} [\mathbf{B}]^T [\mathbf{D}] [\mathbf{B}] d\Omega$ and with $d\Omega = A dx$ for element with constant cross sectional area we obtain:

$$[\mathbf{k}^e] = A \int_0^L \left\{ \begin{matrix} -\frac{1}{L} \\ \frac{1}{L} \end{matrix} \right\} \cdot E \cdot \left[-\frac{1}{L} \quad \frac{1}{L} \right] dx \tag{7.2-a}$$

```

BMat= {D[N1[x,L], {x,2}],D[N2[x,L], {x,2}],D[N3[x,L], {x,2}],D[N4[x,L], {x,2}]} // Simplify
Determine the element stiffness matrix in various forms and shapes;
Integrate[EI Outer[Times,BMat,BMat], {x, 0, L}]
% // MatrixForm
% / (EI/L^3) // Simplify
% // MatrixForm

```

7.3 Triangular Elements

7.3.1 Cartesian Coordinate System (CST)

10 Having retrieved the stiffness matrices of simple one dimensional elements using the principle of virtual displacement, we next consider two dimensional continuum elements starting with the triangular element of constant thickness t made out of isotropic linear elastic material. The element will have two d.o.f's at each node:

$$\{\bar{\mathbf{u}}\} = [u_1 \quad u_2 \quad u_3 \quad v_1 \quad v_2 \quad v_3]^T \quad (7.8)$$

11 The strain displacement relations is required to determine $[\mathbf{B}]$

12 For the 2D plane elasticity problem, the strain vector $\{\boldsymbol{\varepsilon}\}$ is given by:

$$\{\boldsymbol{\varepsilon}\} = [\varepsilon_{xx} \quad \varepsilon_{yy} \quad \gamma_{xy}]^T \quad (7.9)$$

hence we can rewrite the strains in terms of the derivatives of the shape functions through the matrix $[\mathbf{B}]$:

$$\begin{Bmatrix} \varepsilon_{xx} \\ \varepsilon_{yy} \\ \gamma_{xy} \end{Bmatrix} = \underbrace{\begin{bmatrix} \frac{\partial N}{\partial x} & 0 \\ 0 & \frac{\partial N}{\partial y} \\ \frac{\partial N}{\partial y} & \frac{\partial N}{\partial x} \end{bmatrix}}_{[\mathbf{B}]} \begin{Bmatrix} \bar{\mathbf{u}} \\ \bar{\mathbf{v}} \end{Bmatrix} \quad (7.10)$$

13 We note that because we have 3 u and 3 v displacements, the size of $[\mathbf{B}]$ and $\{\bar{\mathbf{u}}\}$ are $9(3 \times 3) \times 6$ and 6×1 respectively.

14 Differentiating the shape functions from Eq. 5.22 we obtain:

$$\underbrace{\begin{Bmatrix} \varepsilon_{xx}^1 \\ \varepsilon_{yy}^1 \\ \gamma_{xy}^1 \\ \varepsilon_{xx}^2 \\ \varepsilon_{yy}^2 \\ \gamma_{xy}^2 \\ \varepsilon_{xx}^3 \\ \varepsilon_{yy}^3 \\ \gamma_{xy}^3 \end{Bmatrix}}_{\{\boldsymbol{\varepsilon}\}} = \underbrace{\begin{bmatrix} \underbrace{-\frac{1}{x_2}}_{\frac{\partial N_1}{\partial x}} & \underbrace{\frac{1}{x_2}}_{\frac{\partial N_2}{\partial x}} & \underbrace{0}_{\frac{\partial N_3}{\partial x}} & 0 & 0 & 0 \\ 0 & 0 & 0 & \underbrace{\frac{x_3 - x_2}{x_2 y_3}}_{\frac{\partial N_1}{\partial y}} & \underbrace{-\frac{x_3}{x_2 y_3}}_{\frac{\partial N_2}{\partial y}} & \underbrace{\frac{1}{y_3}}_{\frac{\partial N_3}{\partial y}} \\ \underbrace{\frac{x_3 - x_2}{x_2 y_3}}_{\frac{\partial N_1}{\partial y}} & \underbrace{-\frac{x_3}{x_2 y_3}}_{\frac{\partial N_2}{\partial y}} & \underbrace{\frac{1}{y_3}}_{\frac{\partial N_3}{\partial y}} & \underbrace{-\frac{1}{x_2}}_{\frac{\partial N_1}{\partial x}} & \underbrace{\frac{1}{x_2}}_{\frac{\partial N_2}{\partial x}} & \underbrace{0}_{\frac{\partial N_3}{\partial x}} \end{bmatrix}}_{[\mathbf{B}]} \underbrace{\begin{Bmatrix} \bar{u}_1 \\ \bar{u}_2 \\ \bar{u}_3 \\ \bar{v}_1 \\ \bar{v}_2 \\ \bar{v}_3 \end{Bmatrix}}_{\{\bar{\mathbf{u}}\}} \quad (7.11)$$

15 With the constitutive matrix $[\mathbf{D}]$ given by Eq. ??, the strain-displacement relation $[\mathbf{B}]$ by Eq. 7.11, we can substitute those two quantities into the general equation for stiffness matrix, Eq. 6.8:

$$[\mathbf{k}^e] = \int_{\Omega} [\mathbf{B}]^T [\mathbf{D}] [\mathbf{B}] d\Omega$$

21 The displacement shape functions are given by Equation 5.50-b:

$$\begin{Bmatrix} L_1 \\ L_2 \\ L_3 \end{Bmatrix} = \frac{1}{2A} \begin{bmatrix} 2A_{23} & y_{23} & x_{32} \\ 2A_{31} & y_{31} & x_{13} \\ 2A_{12} & y_{12} & x_{21} \end{bmatrix} \quad (7.14)$$

where $x_{ij} = x_i - x_j$.

22 Derivatives required for strain-displacement relationships are obtained from Eq. 5.53:

$$\begin{aligned} \frac{\partial L_1}{\partial x} &= \frac{y_2 - y_3}{2A}; & \frac{\partial L_2}{\partial x} &= \frac{y_3 - y_1}{2A}; & \frac{\partial L_3}{\partial x} &= \frac{y_1 - y_2}{2A}; \\ \frac{\partial L_1}{\partial y} &= \frac{x_3 - x_2}{2A}; & \frac{\partial L_2}{\partial y} &= \frac{x_1 - x_3}{2A}; & \frac{\partial L_3}{\partial y} &= \frac{x_2 - x_1}{2A}; \end{aligned} \quad (7.15)$$

23 Then the i th part of the \mathbf{B} matrix becomes:

$$\mathbf{B}_i = \begin{bmatrix} N_{i,x} & 0 \\ 0 & N_{i,y} \\ N_{i,y} & N_{i,x} \end{bmatrix} \quad (i = 1, 2, 3) \quad (7.16)$$

24 The stiffness matrix is then obtained from:

$$\mathbf{K} = \int_{\Omega} \mathbf{B}^T \mathbf{D} \mathbf{B} d\Omega \quad (7.17)$$

25 This expression is then analytically integrated using Eq. 5.59. In general an isoparametric numerical integration is preferred (Section 8.2.3).

7.3.2.2 Quadratic Element (T6)

26 Quadratic displacement shape functions may be written in natural coordinates as:

$$u = \sum_{i=1}^6 N_i u_i \quad v = \sum_{i=1}^6 N_i v_i \quad (7.18)$$

where the shape functions were obtained in Eq. 5.68

$$\begin{aligned} N_1 &= (2L_1 - 1)L_1 & N_4 &= 4L_1 L_2 \\ N_2 &= (2L_2 - 1)L_2 & N_5 &= 4L_2 L_3 \\ N_3 &= (2L_3 - 1)L_3 & N_6 &= 4L_3 L_1 \end{aligned} \quad (7.19)$$

27 It should be noted that alternatively, we could have obtained those shape functions by assuming

$$u(L_1, L_2) = a_1 + a_2 L_1 + a_3 L_2 + a_4 L_1^2 + a_5 L_1 L_2 + a_6 L_2^2 \quad (7.20)$$

and then determine the coefficients through satisfaction of the appropriate boundary conditions.

28 The shape functions and their derivatives with respect to the natural coordinates L_1 and L_2 are given in Table 7.1 (in terms of L_1, L_2 , and L_3).

29 The \mathbf{B} matrix is obtained from:

$$\begin{Bmatrix} \varepsilon_{xx} \\ \varepsilon_{yy} \\ \varepsilon_{xy} \end{Bmatrix} = \underbrace{\begin{bmatrix} \frac{\partial}{\partial x} & 0 \\ 0 & \frac{\partial}{\partial y} \\ \frac{\partial}{\partial y} & \frac{\partial}{\partial x} \end{bmatrix}}_{\mathbf{L}} \begin{Bmatrix} \mathbf{u} \\ \mathbf{v} \end{Bmatrix} \quad (7.21)$$

7.4 Bilinear Rectangular Element

³² The structure stiffness matrix of the bilinear rectangular shown in Fig. 7.1 is described by the

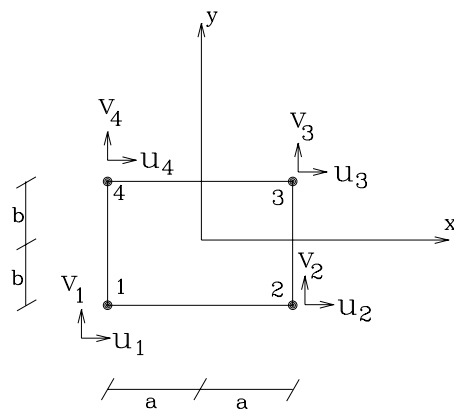

Figure 7.1: Rectangular Bilinear Element

Mathematica code shown below.

```

Define shape functions;
N1[x_,y_,a_,b_] := (1/4)(1-(x/a))(1-(y/b));
N2[x_,y_,a_,b_] := (1/4)(1+(x/a))(1-(y/b));
N3[x_,y_,a_,b_] := (1/4)(1+(x/a))(1+(y/b));
N4[x_,y_,a_,b_] := (1/4)(1-(x/a))(1+(y/b));
Visualize the shape functions;
Plot3D[N1[x,y,1,2], {x, -1, 1}, {y, -2, 2}];
Plot3D[N3[x,y,1,2], {x, -1, 1}, {y, -2, 2}];
Define the differential operators;
diffx[f_] := D[f,x];
diffy[f_] := D[f,y];
Shape Function Matrix
Nmat = {
  {N1[x,y,a,b],0,N2[x,y,a,b],0,N3[x,y,a,b],0,N4[x,y,a,b],0},
  {0,N1[x,y,a,b],0,N2[x,y,a,b],0,N3[x,y,a,b],0,N4[x,y,a,b]}
}
B Matrix
Bmat = {Map[diffx,Nmat[[1]]],Map[diffy,Nmat[[2]]],
  Map[diffy,Nmat[[1]]]+Map[diffx,Nmat[[2]]]}
Define the constitutive matrix
Dmat = E/(1-nu^2) *
  {{1,nu,0},{nu,1,0},{0,0,(1-nu)/2}}
Determine the stiffness matrix
Intmat = Transpose[Bmat] . Dmat . Bmat;
Kmat =Simplify[ t * Integrate[ Integrate[Intmat, {y, -b, b}], {x, -a, a} ]
TeXForm[Kmat]

```

Draft

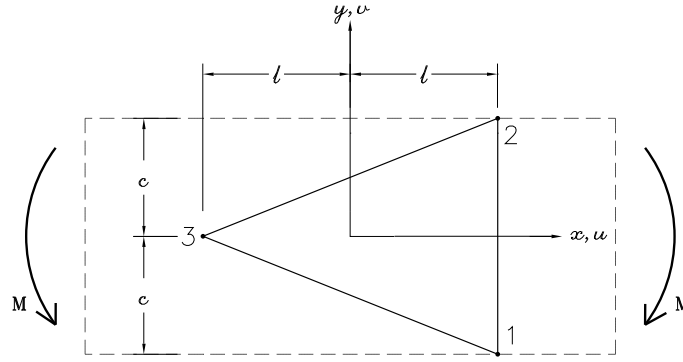

Figure 7.2: Linear Triangular Element Subjected to Pure Bending

38 Imposing nodal displacements consistent with theory ($u_1 = -\bar{u}$, $u_2 = \bar{u}$, and $u_3 = 0$) and similar descriptions for v , and determining the strains from $\boldsymbol{\varepsilon} = \mathbf{B}\bar{\mathbf{u}}$ for the CST element, we obtain

$$\varepsilon_{xx} = 0 \quad \varepsilon_{yy} = 0 \quad \gamma_{xy} = \left(\frac{1}{c} - \nu \frac{c}{4l^2} \right) \bar{u} \quad (7.29)$$

which are clearly wrong. Hence, we conclude the CST element can not properly perform in bending problems (As is expected from a constant strain element behavior when used in a linear strain problem).

39 This deficiency will later be addressed by including an additional internal “drilling” degree of freedom.

40 Zero energy mode can be verified by considering for example the strain ε_{xx} which is given by

$$\varepsilon_{xx} = \frac{1}{x_2 y_3} (-y_3 u_1 + y_3 u_2) \quad (7.30)$$

since $u_1 = u_2$ for a rigid body motion, we see that $\varepsilon_{xx} = 0$, similar conditions can be found for ε_{yy} and ε_{xy}

7.5.2 BiLinear Rectangular

41 Under flexure, the top and bottom sides remain straight giving rise to erroneous strains.

42 From Pascals’s triangle (Sect. 5.4), the displacement field for a bilinear rectangular element is given by

$$u = a_1 + a_2 x + a_3 y + a_5 xy \quad (7.31)$$

which is consistent with the element shape functions derived earlier (Eq. 5.31)

43 We note that whereas there is a quadratic term ($a_5 xy$) convergence is governed by the full linear expansion, and that this last term may cause parasitic effects.

44 For an element with an **inclined** boundary given by $y = ax + b$, insertion of this expression into Eq. 7.31 yields

$$u = a_1 + a_3 b + (a_2 + a_3 a + a_5 b)x + a_5 a x^2 \quad (7.32)$$

hence, u varies quadratically with x along the inclined boundary. However, this boundary is uniquely defined by only two nodal displacements u_1 and u_2 , thus the quadratic expression is not uniquely defined and we may have different variation along the side from one element to the adjacent one.

45 Continuity across the element not being satisfied, the element is **non-conforming**.

Chapter 8

ISOPARAMETRIC ELEMENTS; 2nd GENERATION

8.1 Introduction

- 1 We have previously examined simple finite elements, in this lecture we shall distort those simpler elements into others of more arbitrary shape.
- 2 Correspondingly, the natural coordinates will be distorted into new curvilinear sets when plotted in a cartesian x, y, z space, Fig. 8.1.

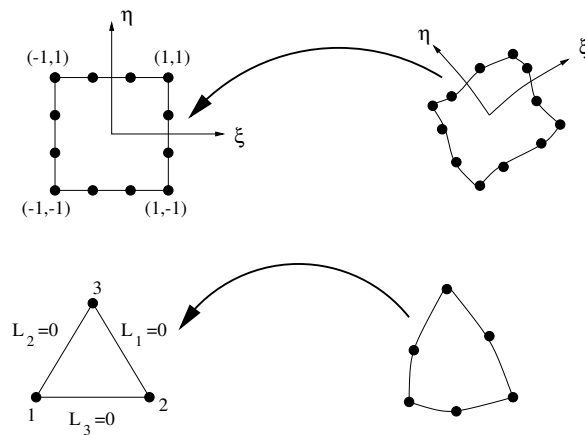

Figure 8.1: Two-Dimensional Mapping of Some Elements

- 3 In the isoparametric formulation, displacements are expressed in terms of natural coordinates, however they must be differentiated with respect to cartesian coordinates x, y, z . This is accomplished through a transformation matrix \mathbf{J} , and integration can no longer be performed analytically but must be done numerically.
- 4 Natural coordinates range from -1 to +1, Fig. 8.2
- 5 Nodal displacements at any point inside the element can be written in terms of the nodal known

Draft

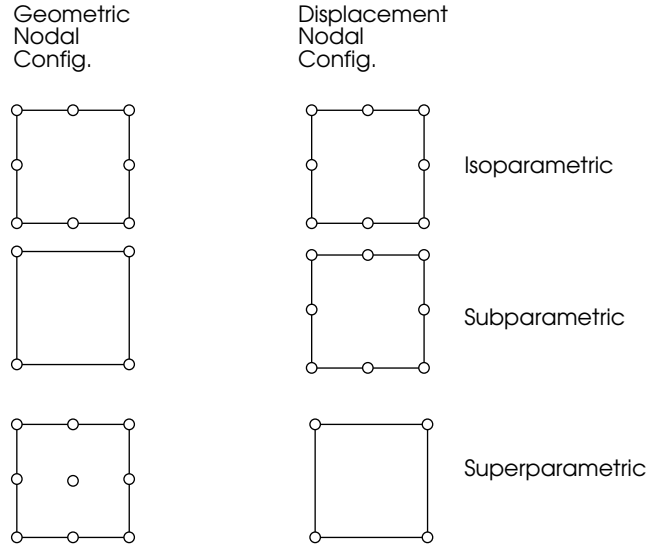

Figure 8.3: Iso, Super, and Sub Parametric Elements

Superparametric: $[N]$ is of lower degree than $[\tilde{N}]$

^s Sub and Super parametric elements are very seldom used.

8.2 Element Formulation

8.2.1 Bar Element

⁹ The simplest introduction to isoparametric elements is through a straight three noded quadratic elements, Fig. 8.4.

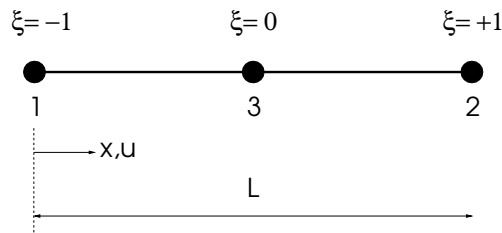

Figure 8.4: Three-Noded Quadratic Bar Element

¹⁰ The shape functions for the element can be obtained from the Lagrangian interpolation function used earlier, Eq. 5.25, and in which we substitute x by ξ . The k th term in a polynomial of order $n - 1$ would be

$$N_k^n = \frac{\prod_{i=1, i \neq k}^n (\xi - \xi_i)}{\prod_{i=1, i \neq k}^n (\xi_k - \xi_i)} \tag{8.5-a}$$

$$= \frac{(\xi - \xi_1)(\xi - \xi_2) \cdots (\xi - \xi_{k-1})(\xi - \xi_{k+1}) \cdots (\xi - \xi_n)}{(\xi_k - \xi_1)(\xi_k - \xi_2) \cdots (\xi_k - \xi_{k-1})(\xi_k - \xi_{k+1}) \cdots (\xi_k - \xi_n)} \tag{8.5-b}$$

17 We observe that \mathbf{B} , in general, contains ξ terms in both the numerator and denominator, and hence the expression can not be analytically inverted. Furthermore, the limits of integration are now from -1 to +1, and we shall see later on how to numerically integrate it.

18 A simple Mathematica code to generate the stiffness matrix of three noded (quadratic) element:

```
x1=0;x2=L;x3=L/2;
N1[x_,L_] :=(x-x2) * (x-x3)/( (x1-x2) * (x1-x3));
N2[x_,L_] :=(x-x1) * (x-x3)/( (x2-x1) * (x2-x3));
N3[x_,L_] :=(x-x2) * (x-x1)/( (x3-x2) * (x3-x1));
BMat={D[N1[x,L],x], D[N2[x,L],x], D[N3[x,L],x]};
Integrate[EA Outer[Times, BMat, BMat], {x,0,L}];
MatrixForm[%]
```

8.2.2 Quadrilaterals

8.2.2.1 Linear Element (Q4)

19 We have previously derived the stiffness matrix of a rectangular element (aligned with the coordinate axis), this formulation will generalize it to an arbitrary quadrilateral shape.

20 Fig. 8.5 illustrates the element

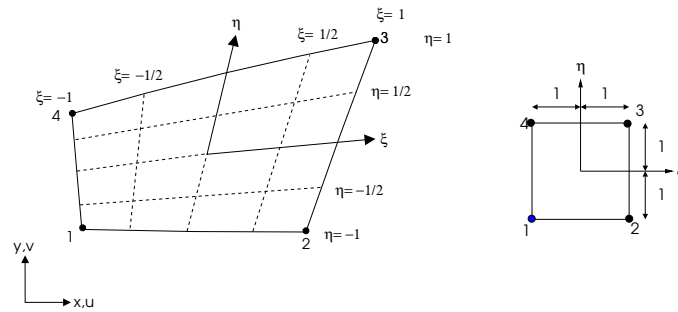

Figure 8.5: Four Noded Isoparametric Element

21 For the two-dimensional case

$$u(\xi, \eta) = \sum N_{ij} \bar{u}_k = \sum_{i=1}^n \sum_{j=1}^m N_j(\xi) N_i(\eta) \bar{u}_k \quad (8.16)$$

where $k = (i - 1)m + j$. For a bilinear element, $n = m = 2$, this can be rewritten as

$$\begin{aligned} u(\xi, \eta) &= \begin{bmatrix} N_1(\xi) & N_2(\xi) \end{bmatrix} \begin{bmatrix} \bar{u}_1 & \bar{u}_3 \\ \bar{u}_2 & \bar{u}_4 \end{bmatrix} \begin{Bmatrix} N_1(\eta) \\ N_2(\eta) \end{Bmatrix} = \mathbf{N}_\xi^T \bar{\mathbf{u}} \mathbf{N}_\eta \\ &= N_1(\xi) N_1(\eta) \bar{u}_1 + N_2(\xi) N_1(\eta) \bar{u}_2 + N_1(\xi) N_2(\eta) \bar{u}_3 + N_2(\xi) N_2(\eta) \bar{u}_4 \\ &= N_1(\xi, \eta) \bar{u}_1 + N_2(\xi, \eta) \bar{u}_2 + N_3(\xi, \eta) \bar{u}_3 + N_4(\xi, \eta) \bar{u}_4 \end{aligned} \quad (8.17-a)$$

$$= \sum_{i=1}^4 N_i \bar{u}_i \quad (8.17-b)$$

22 Applying the Lagrangian interpolation equation, Eq. 8.5-a we obtain

$$N_1(\xi) = \frac{(\xi - \xi_2)}{(\xi_1 - \xi_2)} = \frac{(\xi - 1)}{(-1 - 1)} = \frac{1}{2}(1 - \xi) \quad (8.18-a)$$

Draft

26 Considering the local set of coordinates ξ, η and the corresponding global one x, y , the chain rules would give

$$\begin{Bmatrix} \frac{\partial N_i}{\partial \xi} \\ \frac{\partial N_i}{\partial \eta} \end{Bmatrix} = \underbrace{\begin{bmatrix} \frac{\partial x}{\partial \xi} & \frac{\partial y}{\partial \xi} \\ \frac{\partial x}{\partial \eta} & \frac{\partial y}{\partial \eta} \end{bmatrix}}_{\mathbf{J}} \begin{Bmatrix} \frac{\partial N_i}{\partial x} \\ \frac{\partial N_i}{\partial y} \end{Bmatrix} \quad (8.24-a)$$

$$\begin{Bmatrix} \frac{\partial N_i}{\partial x} \\ \frac{\partial N_i}{\partial y} \end{Bmatrix} = [\mathbf{J}]^{-1} \begin{Bmatrix} \frac{\partial N_i}{\partial \xi} \\ \frac{\partial N_i}{\partial \eta} \end{Bmatrix} \quad (8.24-b)$$

This last equation is the key to get all the components which will go inside the \mathbf{B} matrix.

27 Expanding the definition of the Jacobian

$$\begin{Bmatrix} \frac{\partial N_i(\xi, \eta)}{\partial \xi} \\ \frac{\partial N_i(\xi, \eta)}{\partial \eta} \end{Bmatrix} = \underbrace{\begin{bmatrix} \frac{\partial x}{\partial \xi} & \frac{\partial y}{\partial \xi} \\ \frac{\partial x}{\partial \eta} & \frac{\partial y}{\partial \eta} \end{bmatrix}}_{\mathbf{J}} \begin{Bmatrix} \frac{\partial N_i}{\partial x} \\ \frac{\partial N_i}{\partial y} \end{Bmatrix} = \sum_{i=1}^4 \begin{bmatrix} \frac{\partial N_i}{\partial \xi} \bar{x}_i & \frac{\partial N_i}{\partial \xi} \bar{y}_i \\ \frac{\partial N_i}{\partial \eta} \bar{x}_i & \frac{\partial N_i}{\partial \eta} \bar{y}_i \end{bmatrix} \begin{Bmatrix} \frac{\partial N_i}{\partial x} \\ \frac{\partial N_i}{\partial y} \end{Bmatrix} \quad (8.25-a)$$

$$= \begin{bmatrix} \frac{\partial N_1}{\partial \xi} & \frac{\partial N_2}{\partial \xi} & \frac{\partial N_3}{\partial \xi} & \frac{\partial N_4}{\partial \xi} \\ \frac{\partial N_1}{\partial \eta} & \frac{\partial N_2}{\partial \eta} & \frac{\partial N_3}{\partial \eta} & \frac{\partial N_4}{\partial \eta} \end{bmatrix} \begin{bmatrix} \bar{x}_1 & \bar{y}_1 \\ \bar{x}_2 & \bar{y}_2 \\ \bar{x}_3 & \bar{y}_3 \\ \bar{x}_4 & \bar{y}_4 \end{bmatrix} \begin{Bmatrix} \frac{\partial N_i}{\partial x} \\ \frac{\partial N_i}{\partial y} \end{Bmatrix} \quad (8.25-b)$$

$$= \frac{1}{4} \underbrace{\begin{bmatrix} -(1-\eta) & (1-\eta) & (1+\eta) & -(1+\eta) \\ -(1-\xi) & -(1+\xi) & (1+\xi) & (1-\xi) \end{bmatrix}}_{\mathbf{J}} \begin{bmatrix} \bar{x}_1 & \bar{y}_1 \\ \bar{x}_2 & \bar{y}_2 \\ \bar{x}_3 & \bar{y}_3 \\ \bar{x}_4 & \bar{y}_4 \end{bmatrix} \begin{Bmatrix} \frac{\partial N_i}{\partial x} \\ \frac{\partial N_i}{\partial y} \end{Bmatrix} \quad (8.25-c)$$

28 Back to the Jacobian

$$[\mathbf{J}]^{-1} \stackrel{\text{def}}{=} \begin{bmatrix} \frac{\partial \xi}{\partial x} & \frac{\partial \eta}{\partial x} \\ \frac{\partial \xi}{\partial y} & \frac{\partial \eta}{\partial y} \end{bmatrix} = \frac{1}{\det \mathbf{J}} \begin{bmatrix} \frac{\partial y}{\partial \eta} & -\frac{\partial y}{\partial \xi} \\ -\frac{\partial x}{\partial \eta} & \frac{\partial x}{\partial \xi} \end{bmatrix} = \frac{1}{\det \mathbf{J}} \sum_{i=1}^4 \begin{bmatrix} \frac{\partial N_i}{\partial \xi} \bar{y}_i & -\frac{\partial N_i}{\partial \eta} \bar{y}_i \\ -\frac{\partial N_i}{\partial \eta} \bar{x}_i & \frac{\partial N_i}{\partial \xi} \bar{x}_i \end{bmatrix} \quad (8.26)$$

29 From calculus, if ξ and η are some arbitrary curvilinear coordinates, Fig. 8.6, then

$$d\mathbf{r} = \begin{Bmatrix} \frac{\partial x}{\partial \xi} \\ \frac{\partial y}{\partial \xi} \end{Bmatrix} d\xi \quad \text{and} \quad d\mathbf{s} = \begin{Bmatrix} \frac{\partial x}{\partial \eta} \\ \frac{\partial y}{\partial \eta} \end{Bmatrix} d\eta \quad (8.27)$$

are vectors directed tangentially to $\xi = \text{constant}$, and $\eta = \text{constant}$ respectively.

30 From vector algebra, the cross product of two vectors lying in the x-y plane, Fig. 8.7 is

$$\mathbf{C} = \mathbf{A} \times \mathbf{B} \quad (8.28-a)$$

$$= |\mathbf{A}||\mathbf{B}| \sin \theta \mathbf{k} \quad (8.28-b)$$

$$= \begin{vmatrix} \mathbf{i} & \mathbf{j} & \mathbf{k} \\ A_x & A_y & 0 \\ B_x & B_y & 0 \end{vmatrix} = \underbrace{(A_x B_y - B_x A_y)}_{\text{Area}} \mathbf{k} \quad (8.28-c)$$

$$|\mathbf{C}| = |\mathbf{A}||\mathbf{B}| \sin \theta \quad (8.28-d)$$

Draft

8.6.2.5 bmatps.m

```

function [bmat,dbmat] = bmatps(shape,cardt,D)
%-----
% This function calculates the strain matrix B
%-----
%
%                               VARIABLES
%-----
% shape      Shape function at current point
% cardt      Cartesian shape function derivatives
% bmat       Strain matrix returned by function
% dbmat      Strain matrix * constitutive matrix D
%-----
tic
fprintf('Calculating strain matrix [B]\n')
numcols = 2*length(cardt);
bmat = zeros(3,numcols);
cardtcol = 0;
for ibmatcol = 1:2:numcols
    cardtcol = cardtcol+1;
    bmat(:,ibmatcol:ibmatcol+1) = [cardt(1,cardtcol)      0      ;
                                  0      cardt(2,cardtcol);
                                  cardt(2,cardtcol)   cardt(1,cardtcol)];
end
dbmat = D*bmat;
t = toc;
fprintf(1,'Elapsed time for this operation =%3.4fsec\n\n',t)

```

8.6.3 Plott of Shape Functions

108 Matlab code to generate shape function plots

```

% Shape Functions
X=-1:1/20:1;
Y=X;
YT=Y';
XT=X';
N9=(1-YT.*YT)*(1-X.*X);
N8=0.5*(1-YT.*YT)*(1-X);
N7=0.5*(1-XT.*XT)*(1+Y);
N6=0.5*(1-YT.*YT)*(1+X);
N5=0.5*(1-XT.*XT)*(1-Y);
N4=0.25*(1-XT)*(1+Y)-0.5*(N7+N8);
N3=0.25*(1+XT)*(1+Y)-0.5*(N6+N7);
N2=0.25*(1+XT)*(1-Y)-0.5*(N5+N6);
N1=0.25*(1-XT)*(1-Y)-0.5*(N8+N5);

meshc(X,Y,N1)
print -deps2 shap8-1.eps
c=contour(X,Y,N1);
clabel(c)
print -deps2 shap8-1-c.eps

meshc(X,Y,N8)
print -deps2 shap8-8.eps
c=contour(X,Y,N8);
clabel(c)
print -deps2 shap8-8-c.eps

N1=N1-0.25*N9;
meshc(X,Y,N1)
print -deps2 shap9-1.eps
c=contour(X,Y,N1);
clabel(c)
print -deps2 shap9-1-c.eps

N8=N8-0.5*N9;

```

Chapter 9

ELEMENT FORMULATION and STRAIN RECOVERY in HW FORMULATION

Taken from (Červenka, J. 1994)

9.1 Element Formulation

Taken from (Červenka, J. 1994)

It is necessary to select appropriate interpolation functions for all three elastic fields (i.e. \mathbf{u} , $\boldsymbol{\epsilon}$ and $\boldsymbol{\sigma}$). The choice of these shape functions must be such that the BB condition is satisfied (Appendix ??). In this work, the same interpolation functions are used for all three fields (i.e. displacements, strains and stresses), which implies that there is a full number of unknowns in each node.

$$\dim(\mathbf{u}_n) = N \times \dim - R, \quad \dim(\boldsymbol{\epsilon}_n) = \dim(\boldsymbol{\sigma}_n) = N \times \dim(\boldsymbol{\sigma}) \quad (9.1)$$

where N denotes the number of nodes, \dim is the problem dimension and R is the number of rigid body modes. In Section 9.3, it will be shown that this formulation guarantees the satisfaction of the BB condition.

The polynomial orders of the field approximations are given in Table 9.1.

field	2D		3D	
	T3	T6	T4	T10
displacement \mathbf{u}	linear	quadratic	linear	quadratic
strain $\boldsymbol{\epsilon}$	linear	quadratic	linear	quadratic
stress $\boldsymbol{\sigma}$	linear	quadratic	linear	quadratic

In general case a variable x is interpolated over a finite element using the expression:

$$x = \sum_i^{N_{en}} \Phi_i x_i \quad (9.2)$$

where N_{en} is the number of element nodes, Φ_i is an interpolation function associated with node i , and x_i is the value of variable x at element node i . For the linear triangular element (T3) the interpolation functions are:

$$\Phi_i = l_i, \quad i = 1, 2, 3 \quad (9.3)$$

At the element level, the lumped \mathbf{C} matrix for the four node linear tetrahedron (T4) is:

$$\mathbf{C}_L^e = \begin{bmatrix} 5 & 0 & 0 & 0 \\ 0 & 5 & 0 & 0 \\ 0 & 0 & 5 & 0 \\ 0 & 0 & 0 & 5 \end{bmatrix} \psi \quad (9.11)$$

where ψ is a constant based on the element volume.

CL is by far the simplest strain recovery method since no iterations are required to compute the nodal strains. However, the numerical experiments reported in Section ?? indicate that the displacement solution converges to an erroneous value. Hence, the C-lumping technique is kinematically inconsistent.

9.2.2 Strain smoothing.

Strain Smoothing (Zienkiewicz, Vilotte, Toyoshima and Nakazawa 1985) (SS) is an indirect procedure within *Step 2* that avoids the direct decomposition of the \mathbf{C} matrix. Nodal strains are iteratively evaluated until the ratio of the Euclidean norms of strain correction to total strains satisfies a prescribed limit.

This technique exploits the diagonal matrix \mathbf{C}_L previously described and the consistent matrix \mathbf{C} defined below. Iteratively the nodal strains are evaluated by:

$$\boldsymbol{\epsilon}_n^{j+1} = \boldsymbol{\epsilon}_n^j + \mathbf{C}_L^{-1}(\mathbf{E}\mathbf{u}_n - \mathbf{C}\boldsymbol{\epsilon}_n^j). \quad (9.12)$$

where $j = 0, 1, 2, \dots$ is the strain-iteration count. Note that this represents an internal iteration, not to be confused with the MIM iteration of (??). The iteration process involves the nodal strains in the whole mesh since *Step 2* is equivalent to the least square fit of the nodal based strain field to the strain field derived from the displacement field (Zienkiewicz and Taylor 1989).

For a four noded linear tetrahedral element (T4), the consistent matrix \mathbf{C} is given at the element level by:

$$\mathbf{C}^e = \int_{\Omega_e} \boldsymbol{\Phi}\boldsymbol{\Phi}^T d\Omega = \begin{bmatrix} 2 & 1 & 1 & 1 \\ 1 & 2 & 1 & 1 \\ 1 & 1 & 2 & 1 \\ 1 & 1 & 1 & 2 \end{bmatrix} \psi \quad (9.13)$$

where ψ is again a constant based on the element volume.

The correction of nodal strain $\Delta\boldsymbol{\epsilon}_n^j$ during one iteration is:

$$\Delta\boldsymbol{\epsilon}_n^j = \boldsymbol{\epsilon}_n^{j+1} - \boldsymbol{\epsilon}_n^j = \mathbf{A}(\rho)\Delta\boldsymbol{\epsilon}_n^{j-1}, \quad (j \geq 1) \quad (9.14)$$

where:

$$\mathbf{A}(\rho) = \mathbf{I} - \mathbf{C}_L^{-1}\mathbf{C} \quad (9.15)$$

where $\mathbf{A}(\rho)$ is a fixed amplification matrix having a spectral radius $\rho = \frac{4}{5}$. The spectral radius ρ is defined as the largest eigenvalue of amplification matrix $\mathbf{A}(\rho)$. Since Equation 9.15 involves a product of \mathbf{C} and inverse of \mathbf{C}_L , the constants ψ are cancelled out. By Banach's fixed point theorem (Haser and Sullivan 1991) it is necessary for the spectral radius ρ to be less than 1 to ensure convergence of the iterative process given by Equation 9.12. Thus, this value of the spectral radius indicates an error decay of $\frac{1}{5}$.

9.2.3 C-splitting.

A new iterative process was recently developed by (Červenka, Keating and Felippa 1993) to solve *Step 2*. This new technique guarantees faster convergence for linear triangular and tetrahedral elements (T3 and T4). This technique is referred to as C-splitting (CS). This method “splits” the consistent matrix \mathbf{C} of Equation 9.13 into two matrices. One matrix is diagonalized and the second is formed such that their algebraic sum is equivalent to the original \mathbf{C} matrix:

$$\mathbf{C} = \mathbf{C}_D + \mathbf{C}_R \quad (9.16)$$