

BIOLOGICAL PROCESSES WITH MULTIPLE ZONES

PROCESS CONSIDERATIONS FOR NITROGEN REMOVAL VIA NITRIFICATION AND DENITRIFICATION IN CELL RECYCLE SYSTEM

DENITRIFICATION

- ASSIMILATORY (NO₃⁻ used for cell synthesis) NO₃⁻ → organic N
- DISSIMILATORY (NO₃⁻ is e⁻ acceptor in respiration) NO₃⁻ → N₂ typically. Dissimilatory process carried out by facultative heterotrophs (genera: *Pseudomonas*, *Paracoccus*, *Hyphomicrobium*, *Alcaligenes*, and others) is used in wastewater treatment. May also produce NO₂⁻, N₂O, even NH₄⁺ **PROCESS DESIGN BASED ON DISSIMILATORY DENITRIFICATION, OR NITRATE RESPIRATION.**

ENERGETICS OF RESPIRATION.

ORDER OF ENERGY PROVIDED BY e⁻ ACCEPTORS:

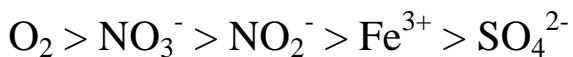

So anoxia is a condition for denitrification by facultative bacteria, which would use oxygen preferentially for energy production if available.

DENITRIFICATION PROCESS STOICHIOMETRY (MOLAR)

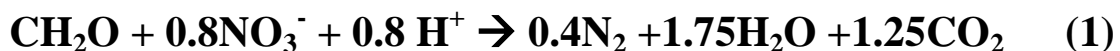

COMPARE WITH AEROBIC RESPIRATION

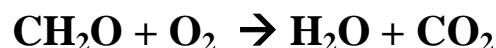

Compare e⁻ acceptor consumption/gram carbohydrate:

$$1 \text{ mole}(32\text{g/mole}) \text{O}_2 / 0.8 \text{ mole}(14\text{g/mole})\text{-NO}_3\text{-N} = \mathbf{2.86 \text{ g- O}_2/\text{g- NO}_3\text{-N}}$$

each gram on nitrate consumed in respiration saves **2.86** gram oxygen

COD-BASED WITH GROWTH (CELLS AS REFERENCE):

$$(-1/Y_H)S_S - ((1-Y_H)/2.86Y_H)S_{NO} + X_{BH} = 0 \quad (2)$$

ALKALINITY EFFECTS

NITRIFICATION (MOLAR STOICHIOMETRY, NEGLECT GROWTH):

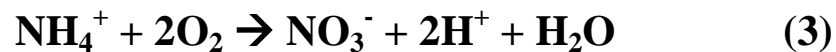

(2eq alkalinity consumed/mole NH_4^+ -N oxidized)*50 g- CaCO_3 /14 g-N/mole =..
...= **7.1 g- CaCO_3 consumed/g- NH_4^+ -N oxidized**

and **4.57 g- O_2 /g- NH_4^+ -N oxidized**

DENITRIFICATION

From (1):

1eq alkalinity produced/mole NO_3^- -N reduced)*50 g- CaCO_3 /14 g-N/mole = ...
...= **3.6 g- CaCO_3 produced/g- NO_3^- -N reduced**

Denitrification Recovers Alkalinity and Oxygen:

Net alkalinity consumption = 7.1 – 3.6 = ...
...= 3.5 g- CaCO_3 consumed/g- NH_4^+ -N oxidized and reduced)

Net oxygen consumption = 4.57 – 2.86 = ...
... = 1.8 g- O_2 /g- NH_4^+ -N oxidized and reduced)

**SUSPENDED GROWTH REACTORS WITH MULTIPLE ZONES
NITRIFICATION FOLLOWED BY DENITRIFICATION (ALSO "AIR ON-OFF"
OPERATION)**

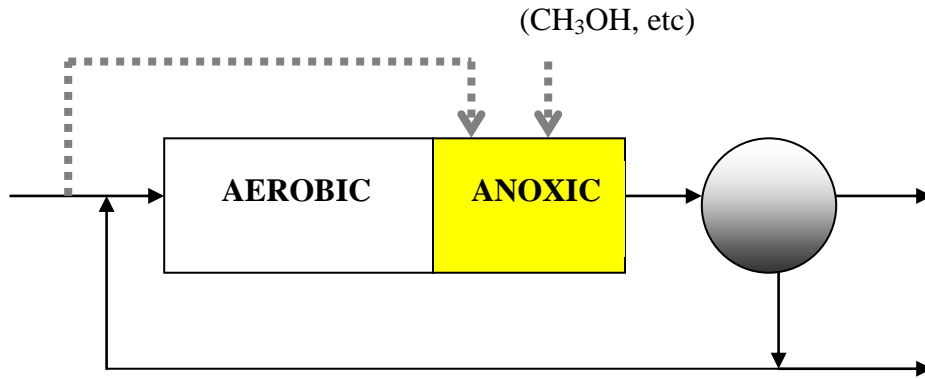

MODIFIED LUDZACK-ETTINGER PROCESS (MLE)

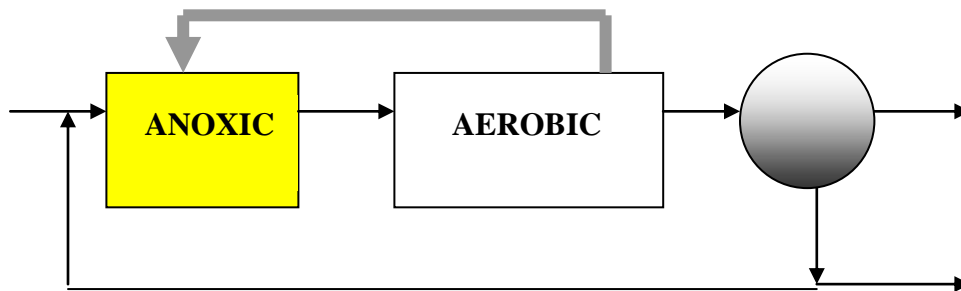

THREE-STAGE BARDENPHO PROCESS

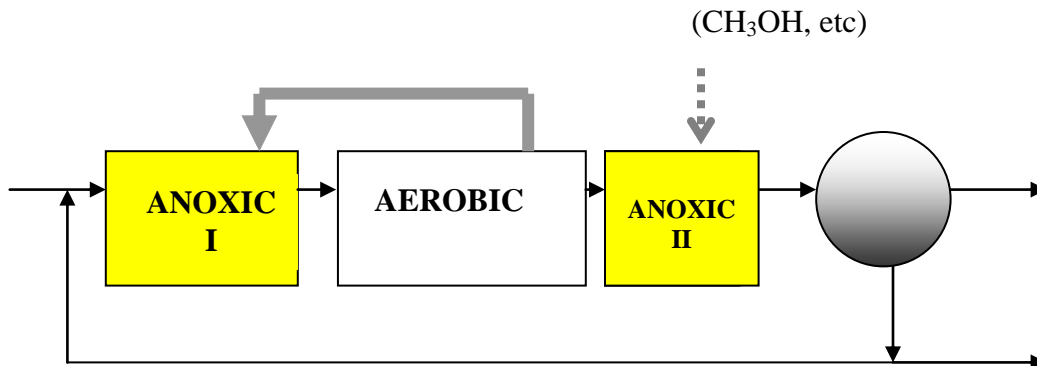

CONSTRAINED DESIGN PROEDURE FOR DENITRIFICATION PROCESSES THAT USE NITRATE RECIRCULATION (MLE AND BARDENPHO). NOT “FORWARD” MASS BALANCE APPROACH AS WAS USED FOR COD AND AMMONIA OXIDATION (NITRIFICATION)

CONSTRAINING FACTORS

1. TIME BIOMASS SPENDS IN APPROPRIATE PROCESS ZONE
2. COD SUBSTRATE AVAILABLE FOR DENITRIFICATION
3. NITRATE RECIRCULATION RATE

1. Define a solids retention time for each zone based on fraction of total solids retention time cells are aerated and anoxic to zone volumes:

$$f_{XM,aer} = \Theta_{aer}/\Theta = \Sigma_i(V_i X_{Bi})_{aer}/(V X_B)_{system}$$

$$f_{XM,anox} = \Theta_{anox}/\Theta = \Sigma_i(V_i X_{Bi})_{anox}/(V X_B)_{system}$$

where $f_{XM,i}$ = fraction that biomass of concentration X_{Bi} spends in a zone, i , characterized as aerated (aer) or unaerated (anox), with volume, V_i , where $\Theta_i = \Sigma_i(V_i X_{Bi})/Q_w X_w$, $\Theta = (V X_B)_{system}/Q_w X_w$, and $\Sigma_i \Theta_i = \Theta$.

Assume that biomass concentration is uniform throughout system (cell recirculation is more significant in determining X_{Bi} than growth. Then:

$$\Theta_{aer}/\Theta = \Sigma_i(V_i)_{aer}/(V)_{system} \quad (4)$$

and

$$\Theta_{anox}/\Theta = \Sigma_i(V_i)_{anox}/(V)_{system} \quad (5)$$

For example, for an MLE process:

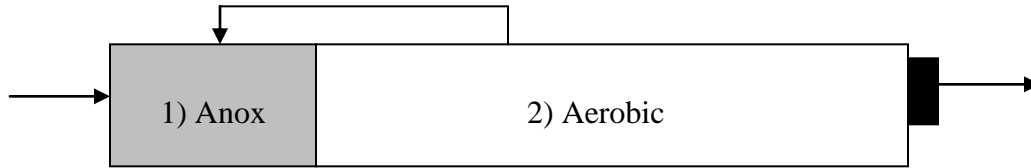

Given: $V_1 = 3,000 \text{ m}^3$, $V_2 = 7,000 \text{ m}^3$, and $\Theta = 7 \text{ d}$, then

$$\Theta_{\text{anox}} = 2.1 \text{ d and } \Theta_{\text{aer}} = 4.9 \text{ d}$$

For an MLE PROCESS with one aerobic and one anoxic zone:

$$V_{\text{system}} = V_{\text{aer}} + V_{\text{anox}}$$

And

$$\Theta = \Theta_{\text{anox}} + \Theta_{\text{aer}} \quad (6)$$

Substituting (6) into (4) and (5) for the following relation:

$$V_{\text{anox}}/V_{\text{aer}} = \Theta_{\text{anox}}/(\Theta - \Theta_{\text{anox}}) = (\Theta - \Theta_{\text{aer}})/\Theta_{\text{aer}}$$

2. COD REQUIREMENT FOR DENITRIFICATION

O₂ consumption rate, RO, for aerobic respiration,

$$RO \text{ (g-O}_2\text{/day)} = Q(S_{SO} - S_S)(1 - Y_{Hobs}) \quad (\text{g-O}_2\text{/d)}$$

For denitrification, equivalent nitrate consumption rate, RO_N, expressed as oxygen equivalents:

$$RO_N = 2.86 \cdot RNO \text{ (g- O}_2\text{/day)} = 2.86 \cdot Q \cdot (S_{NNO} - S_{NO})$$

Where

RO_N = rate of nitrate consumption expressed as oxygen equivalents

RNO = mass rate of nitrate consumption (kg/d) = Q*(S_{NNO}-S_{NO})

S_{NNO} = soluble nitrate nitrogen influent to anoxic tank or zone (mg/L N)
 S_{NO} = anoxic tank concentration of soluble nitrate nitrogen (mg/L N)
 Q = flow rate (m^3/d)

Since nitrate is expressed as oxygen equivalents, now can write

$$RO_N = 2.86Q(S_{NNO} - S_{NO}) = Q(S_{SO} - S_S)_N(1 - Y_{Hobs}) \quad (g-O_2/d) \quad (7)$$

Since the mass of substrate COD oxidized during denitrification in the anoxic zone, $(S_{SO} - S_S)_N(1 - Y_{Hobs})$, accounts for the mass of nitrate reduced, expressed as oxygen.

Where $(S_{SO} - S_S)_N$ represents the COD consumed during denitrification

$$\begin{aligned} \text{COD required per amount of denitrification in terms of N} = \\ \Delta S_{S,N}/\Delta N = -Q(S_{SO} - S_S)_N/Q(S_{NNO} - S_{NO}) \end{aligned}$$

Rearranging and substituting $\Delta S_{S,N}/\Delta N$ into (7):

$$\Delta S_{S,N}/\Delta N = 2.86/(1 - Y_{Hobs}) = 2.86(1 + b_H \Theta_{anox}) / (1 + b_H \Theta_{anox} - Y_H(1 + f_D b_H \Theta_{anox}))$$

(8)

Where Y_{Hobs} is a function of Θ_{anox} , rather than Θ , assuming the heterotrophic decay coefficient, b_H , doesn't change under denitrifying conditions.

note different effects of Θ on oxygen consumption and on denitrification:

In aerobic processes, the principal concern is the increase in oxygen required because as Θ_{aer} increases, decay becomes more important in the biological process, since soluble COD and ammonia are recycled: as $\Theta \uparrow$, $RO \uparrow$ (more decay, more soluble COD produced, more oxygen consumption, HIGHER COST)

In denitrification the principal concern is the simultaneous utilization of nitrate and COD. As $\Theta_{\text{anox}} \uparrow$, the consumption of influent substrate per unit mass nitrate reduced, $\Delta\text{COD}/\Delta\text{N}, \downarrow$ since decay creates more soluble substrate. Two effects: 1) If influent COD is relatively low for the amount of nitrate to be reduced in denitrification, long values of Θ_{anox} can be advantageous since the amount of nitrate to be reduced is higher than influent COD. 2) However, if influent COD is high, then the extra COD supplied by biomass decay will consume nitrate in the anoxic zone, leading to higher consumption of oxygen later in the aerobic zone, if all soluble COD is to be oxidized, and HIGHER COST.

Selected Θ_{anox} should result in maximum consumption of influent COD and generated nitrate in anoxic zone and minimum oxygen required in aerobic zone. Graph (eq 8) below shows second (high influent COD) effect: long $\Theta_{\text{anox}} \rightarrow$ less influent COD consumed per mass nitrate reduced \rightarrow greater oxygen requirement. Typically $5 < \Delta\text{S}_{\text{S,N}}/\Delta\text{N} < 9 \text{ g-COD/g-NO}_3\text{-N}$

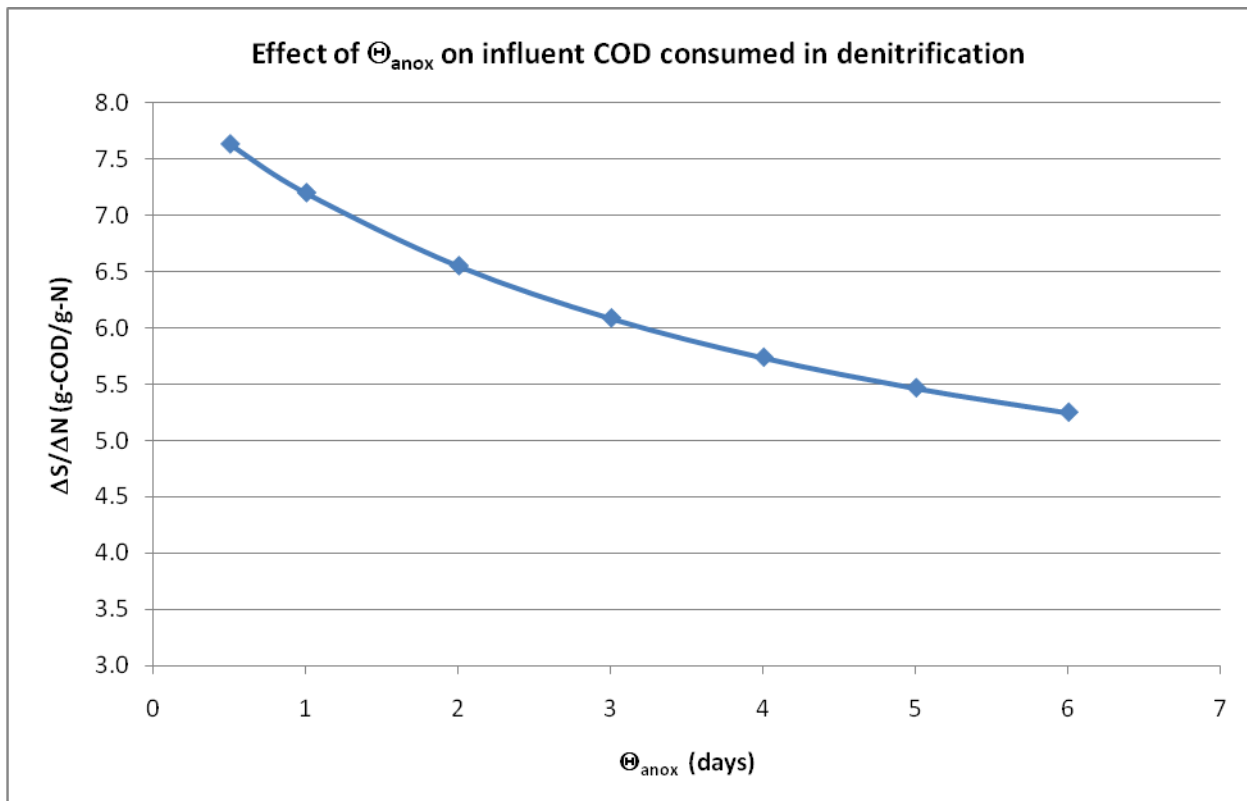

3. NITRATE RECIRCULATION, or MIXED LIQUOR RECIRCULATION (MLR)

Process constraint, providing sufficient nitrate for maximizing COD removal and saving oxygen.

Invert (8):

$$\Delta N / \Delta S_{S,N} = (1 + b_H \Theta_{\text{anox}} - Y_H (1 + f_D b_H \Theta_{\text{anox}})) / 2.86 (1 + b_H \Theta_{\text{anox}}) \quad (\text{g-N/g-COD}) \quad (9)$$

$$\Delta N = \Delta S_{S,N} (1 + b_H \Theta_{\text{anox}} - Y_H (1 + f_D b_H \Theta_{\text{anox}})) / 2.86 (1 + b_H \Theta_{\text{anox}}) \quad (\text{g-N/g-COD}) \quad (9a)$$

Available nitrate for denitrification (S_{NO}) is calculated assuming that influent nitrogen is either stored in heterotrophic cells (neglect autotroph cell growth), oxidized to nitrate or in effluent:

$$S_{\text{NO}} = Q(S_{\text{NHO}} + S_{\text{NSO}} + X_{\text{NSO}} - NR(S_{\text{SO}} - S_S) - S_{\text{NH}} - S_{\text{NS}}) \quad (\text{g-N/d})$$

Formula assumes influent ammonia, soluble and particulate organic nitrogen ($S_{\text{NHO}} + S_{\text{NSO}} + X_{\text{NSO}}$) minus cell synthesis and effluent soluble ammonia and organic nitrogen is available nitrate

Define the fraction of available nitrate that can be denitrified, S_{NO} , in the anoxic zone, $f_{\text{NO,D}}$, which is a function of available substrate COD (from 8)

$$f_{\text{NO,D}} = \Delta N / S_{\text{NO}} = \Delta N / [(S_{\text{NHO}} + S_{\text{NSO}} + X_{\text{NSO}} - X_{\text{Ncells}} - S_{\text{NH}} - S_{\text{NS}})] \quad (10)$$

For the MLE system shown below, the introduce the term fraction of nitrate produced in the aerobic tank that is recirculated (assuming negligible nitrate in the influent to the aerobic tank):

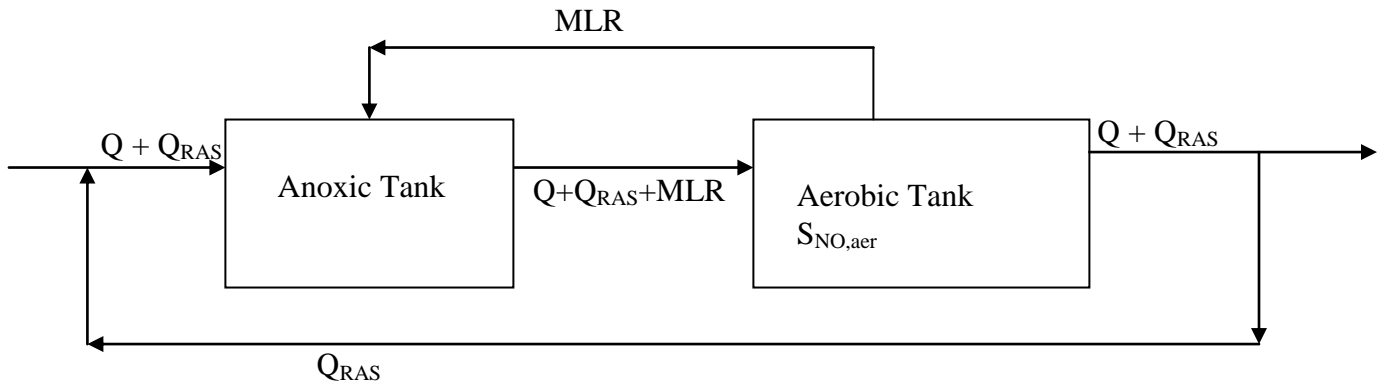

$f_{NO,R} = (\text{NO}_3\text{-N flow into anoxic zone})/(\text{NO}_3\text{-N flow out of aerobic zone})$

$$f_{NO,R} = [(MLR + Q_{RAS})S_{NO,aer}]/[(Q + MLR + Q_{RAS})S_{NO,aer}]$$

where $S_{NO,aer}$ = nitrate concentration in aerobic tank and in both flows,
 MLR = mixed liquor recirculation flow rate from aerobic to anoxic tank,
 Q = system influent flow rate, Q_{RAS} = recycled biomass flow rate from secondary clarifier.

divide numerator and denominator by Q and define:

$$\alpha = Q_{RAS}/Q$$

and

$$\beta = MLR/Q$$

$$f_{NO,R} = (\alpha + \beta)/(1 + \alpha + \beta)$$

Rearranging to solve for the recirculation/recycle flow rate design values:

$$(\alpha+\beta) = f_{\text{NO,R}}(1+\alpha+\beta) = f_{\text{NO,R}} + f_{\text{NO,R}}(\alpha+\beta)$$

$$f_{\text{NO,R}} = (\alpha+\beta)(1-f_{\text{NO,R}})$$

$$(\alpha+\beta) = f_{\text{NO,R}} / (1-f_{\text{NO,R}}) \quad (11)$$

Objective: set α and β such that $f_{\text{NO,R}} = f_{\text{NO,D}}$ from (10), that is, design the recirculation/recycle flows such that the recirculated fraction equals the fraction of available nitrate that can be denitrified, given a limited supply of COD. After substituting $f_{\text{NO,D}}$ for $f_{\text{NO,R}}$ from (10)

$$\alpha + \beta = f_{\text{NO,D}} / (1-f_{\text{NO,D}}) \quad (12)$$

SUMMARY

Process factors control denitrification in a recirculation process:

- I. **Ratio of available COD to nitrate reduction (g-COD/g-NO₃-N reduced) which is a function of Θ_{anox} (Equation 8)**
- II. **Recirculation of nitrified water, β (Equation 11)**
- III. **Recycled biomass flow rate, α (which has a lesser effect and is usually fixed by considerations that have nothing to do with denitrification, e.g., secondary clarifier performance and solids wasting rate)**

Design procedure for MLE process:

1. **Select Θ_{anox} (typically between 1 and 3 d)**
2. **Calculate $\Delta\text{N}/\Delta\text{S}_{\text{S,N}}$ using (9)**
3. **Calculate attainable ΔN assuming complete consumption of influent COD**
4. **calculate $f_{\text{NO,D}}$ from (10)**
5. **Calculate $\alpha + \beta$ from (12). Select α based on secondary clarifier requirements and wasting rate, usually in range 0.25 to 1 to get β**